

Parts Manual

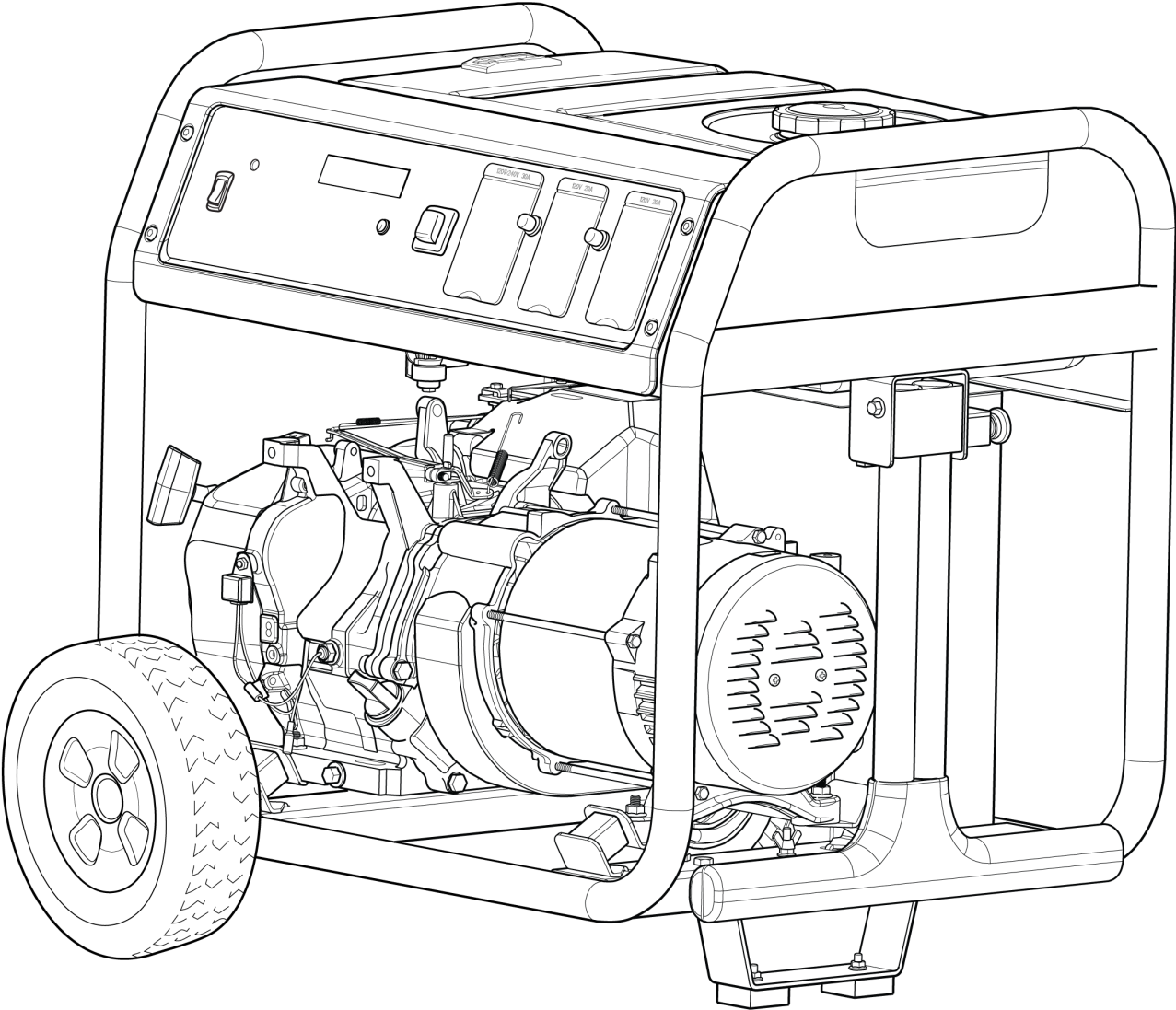

Watt Storm Generator, Briggs & Stratton 49 State



Model Components	Page
Alternator.....	4
Control Panel.....	6
Engine (80005671).....	8
Main Unit.....	12
Wheel Kit.....	16
Wiring Diagram.....	18
Wiring Schematic.....	20
Torque Specification Chart.....	22

Not For
Reproduction

Alternator

Note: Unless noted otherwise, use the standard torque specifications

030728-04- 6,250 Watt Storm Generator, Briggs & Stratton 49 State

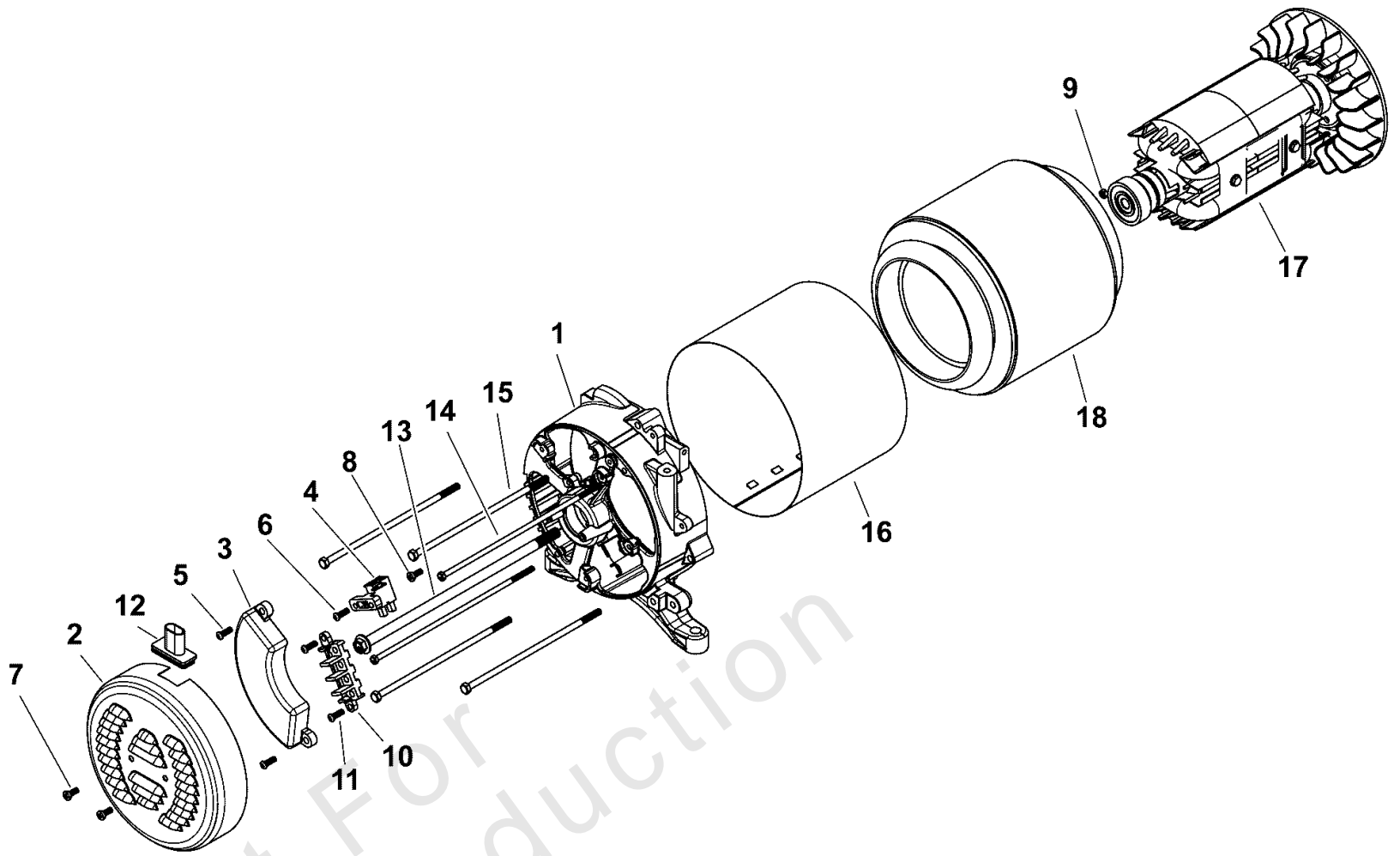

Not For
Reproduction

Alternator

REF NO	PART NO	QTY	DESCRIPTION
1	312866GS	1	SUPPORT, Bearing
2	312870GS	1	COVER, Rear Bearing
3	312871GS	1	REGULATOR-VOLTAGE
4	312904GS	1	BRUSH ASSEMBLY
5	312907GS	2	SCREW
6	312908GS	1	SCREW
7	312909GS	2	SCREW
8	312911GS	1	SCREW
9	312916GS	2	NUT
10	312921GS	1	BLOCK, Junction
11	312922GS	2	SCREW
12	703013	1	COVER, Alternator, Rubber
13	703910	1	BOLT
14	703908	2	BOLT
15	703909	4	BOLT
16	703911	1	BAND-STATOR
17	706902	1	ROTOR
18	706903	1	STATOR

Not For Reproduction

Control Panel

Note: Unless noted otherwise, use the standard torque specifications

030728-04- 6,250 Watt Storm Generator, Briggs & Stratton 49 State

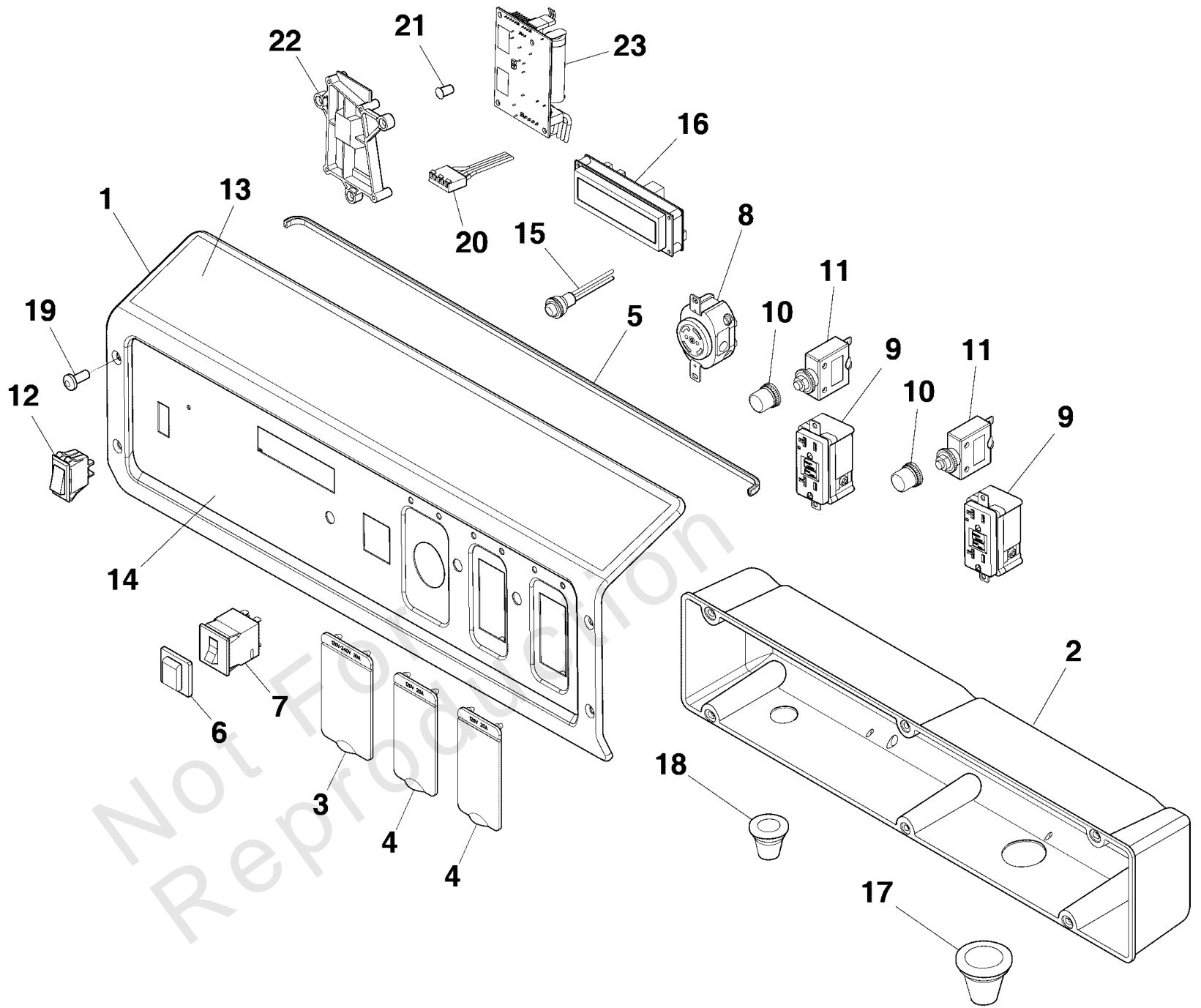

Control Panel

REF NO	PART NO	QTY	DESCRIPTION
1	772210	1	PANEL-CONTROL -(Includes Item 13 & 14)
2	772214	1	BOX-CONTROL-PANEL
3	319477GS	1	COVER-OUTLET
4	319476GS	2	COVER-OUTLET
5	319459GS	1	TRIM-EDGE
6	191481GS	1	BOOT, Breaker Circuit
7	319540GS	1	BREAKER-CIRCUIT
8	43437GS	1	OUTLET, 120/240V Locking, 30A
9	709526	2	OUTLET-GFCI
10	312636GS	2	BOOT, Circuit Breaker
11	209872GS	2	BREAKER-CIRCUIT 20A
12	319525GS	1	SWITCH-ON/OFF
13	772212	1	DECAL
14	772216	1	DECAL
15	319463GS	1	BUTTON-SELECT
16	318458GS	1	POWER MONITOR
17	319529GS	1	GROMMET
18	319530GS	1	GROMMET
19	772229	4	SCREW
20	772215	1	WIRE-HARNESS-CO
21	772217	1	LIGHT-PIPE
22	772213	1	BRACKET-MODULE
23	84005244	1	MODULE-CO

Engine (80005671)

Note: Unless noted otherwise, use the standard torque specifications

030728-04- 6,250 Watt Storm Generator, Briggs & Stratton 49 State

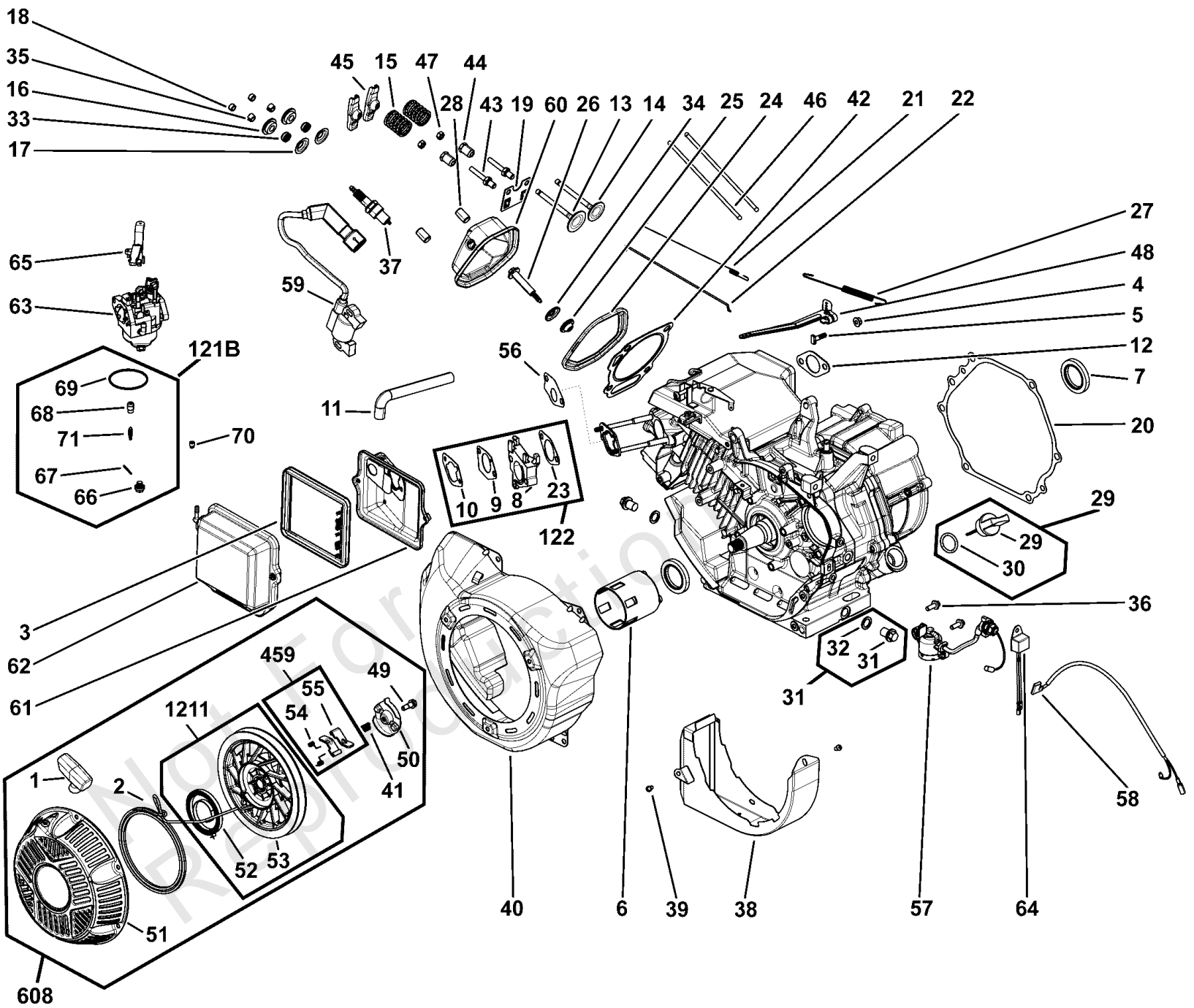

Engine (80005671)

REF NO	PART NO	QTY	DESCRIPTION
1	691915	1	GRIP, Starter Rope
2	693389	1	ROPE, Starter
3	491588S	1	FILTER, A/C Cartridge
4	690939	1	NUT
5	797230	1	BOLT
6	797746	1	CUP, Flywheel
7	797766	1	SEAL, Oil
8	799961	1	SPACER, Carburetor
9	797755	1	GASKET, Intake
10	797756	1	GASKET, Air Cleaner
11	797768	1	TUBE, Breather
12	797770	1	GASKET, Exhaust
13	594256	1	VALVE, Intake
14	594257	1	VALVE, Exhaust
15	797780	2	SPRING, Valve
16	797781	2	RETAINER, Valve
17	797782	2	RETAINER, Valve
18	797784	2	CAP, Valve
19	797787	1	GUIDE, Push Rod
20	797789		GASKET, Crankcase
21	797809	1	SPRING, Governor Link
22	797810	1	LINK, Mechanical Governor
23	797845	1	GASKET, Intake
24	797846	1	GASKET, Rocker Cover
25	797847	1	WASHER, Sealing
26	797848	1	SCREW
27	797843	1	SPRING, Governor
28	797792	1	PIN, Locating
29	797762	1	PLUG, Dipstick/Fill -(Includes Items 29 & 30)
30	797763	1	SEAL, O-Ring
31	797793	2	PLUG, Oil Drain -(Includes Items 31 & 32)
32	797794	2	WASHER
33	797854	2	SEAL, Valve
34	797847	1	WASHER, Sealing
35	797783	4	KEEPER, Valve
36	798975	2	SCREW
37	798615	1	PLUG, Spark
38	798839	1	SHIELD, Crankcase
39	798840	2	SCREW
40	799968	1	HOUSING, Blower
41	799669	1	SPRING, Friction
42	799534	1	GASKET, Cylinder Head
43	591088	2	STUD, Rocker Arm -(Includes items 43, 44 & 47)
44	-----	2	NUT, Hex -(Included in item 43)
45	591087	2	ARM, Rocker
46	799966	2	ROD, Push
47	-----	2	*NUT, Lock -(Included in item 43)
48	799924	1	LEVER, Governor Control -(Includes items 4, 5 & 48)

Engine (80005671)

Note: Unless noted otherwise, use the standard torque specifications

030728-04- 6,250 Watt Storm Generator, Briggs & Stratton 49 State

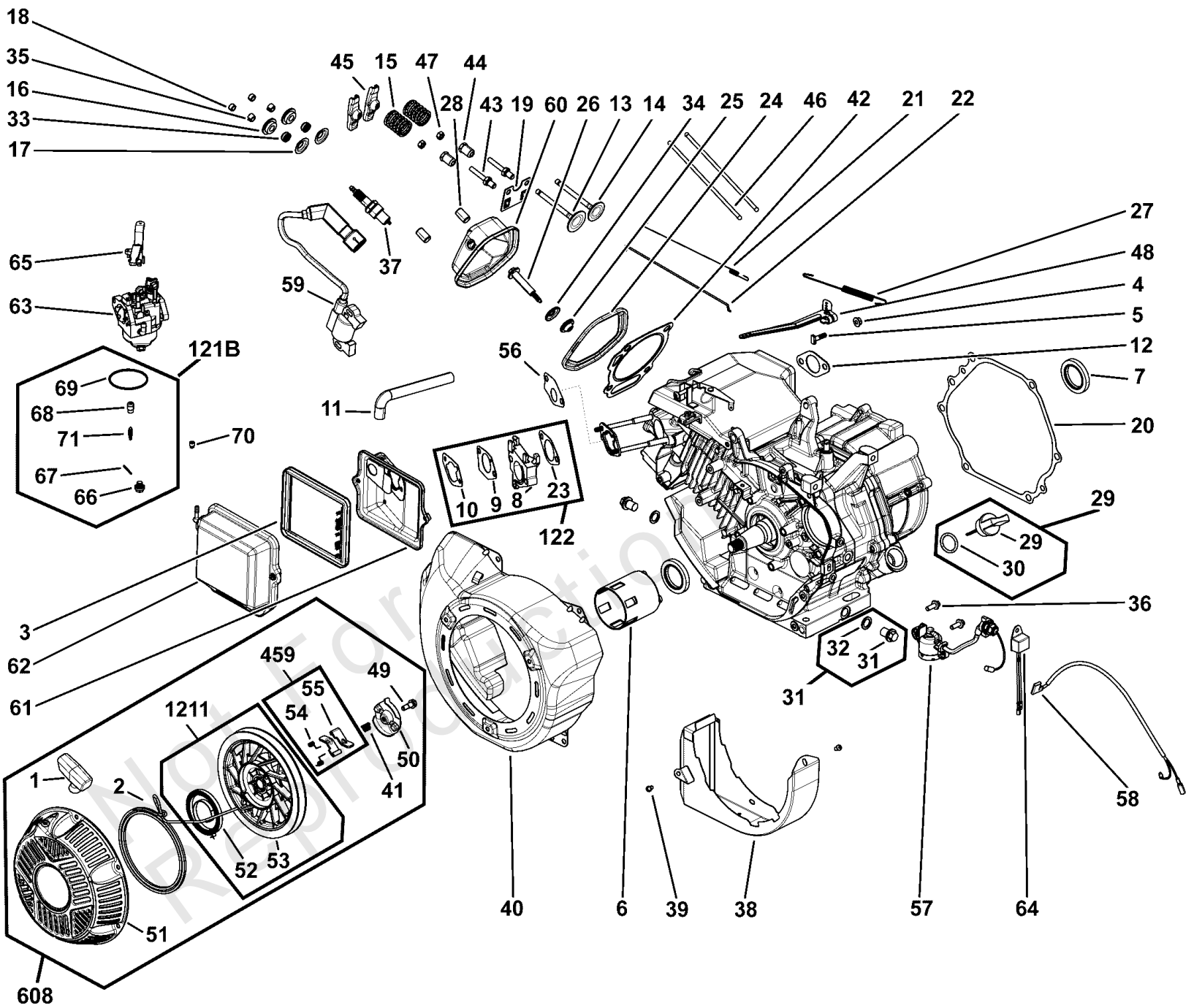

Engine (80005671)

REF NO	PART NO	QTY	DESCRIPTION
49	799972	1	SCREW
50	799973	1	PLATE, Pawl Friction
51	799974	1	HOUSING, Rewind Starter
52	-----	1	SPRING, Recoil
53	-----	1	PULLEY, Recoil
54	-----	2	SPRING, Pawl
55	-----	2	Pawl-Ratchet
56	592652	1	GASKET, Intake
57	797771	1	SENSOR, Oil
58	797856	1	HARNES, Wiring
59	798616	1	ARMATURE, Magneto
60	799778	1	COVER, Rocker -(Includes Gaskets, Sealing Washer)
61	799776	1	BASE, Air Cleaner -(Includes A/C Gasket Item 10 & Fuel Connector Cap Not Illustrated)
62	590958	1	COVER, Air Cleaner
63	592929	1	CARBURETOR -(Includes Items 9, 10, 23 & 63)
64	84004388	1	MODULE, Oil Sensor
65	797759	1	LEVER, Choke
66	-----	1	SCREW, Bowl Mounting
67	-----	1	PIN, Float
68	-----	1	SEAT, Inlet
69	-----	1	GASKET, Float Bowl
70	592928	1	JET, Main
71	-----	1	ASSEMBLY, Needle Fuel Inlet
121B	592332	1	KIT, Carburetor Overhaul -(Includes Items 9, 10, 23, 66, 67,68, 69 & 71)
122	799961	1	SPACER, Carburetor
459	799976	1	PAWL, Ratchet
608	797747	1	STARTER, Rewind
1211	799975	1	PULLEY/SPRING ASSEMBLY

Main Unit

Note: Unless noted otherwise, use the standard torque specifications

030728-04- 6,250 Watt Storm Generator, Briggs & Stratton 49 State

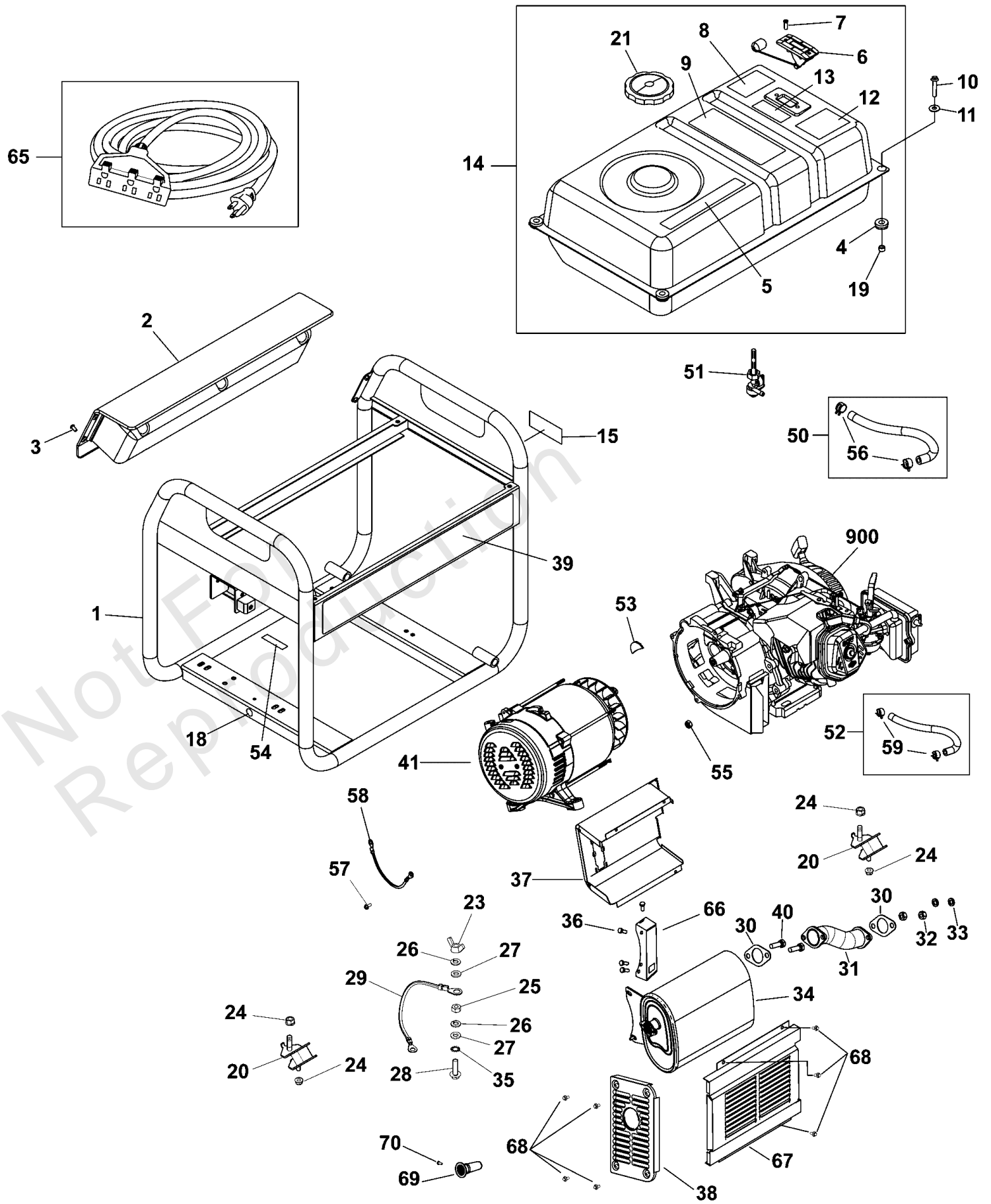

Main Unit

REF NO	PART NO	QTY	DESCRIPTION
1	-----	1	CRADLE
2	REF-80029808	1	Refer to: Control Panel Group
3	772229	4	SCREW
4	189134GS	4	GROMMET, Rubber
5	772237	1	DECAL
6	704183	1	GAUGE-FUEL
7	314440GS	2	SCREW
8	772233	1	DECAL
9	84007365	1	DECAL
10	703805	4	SCREW
11	312005GS	4	WASHER
12	202997GS	1	DECAL, Warning, CO
13	703264	1	DECAL
14	772227	1	TANK-FUEL
15	772236	1	DECAL
18	704331	1	DECAL
19	189137GS	4	SPACER
20	319451GS	4	MOUNT-VIBRATION
21	319587GS	1	CAP-FUEL
23	87680GS	1	NUT, M6 - 1.0 Wing
24	67989GS	8	NUT, M8 Flange Serrated
25	49813GS	1	NUT, Hex, M6 - 1.0
26	22097GS	2	WASHER
27	49811GS	2	WASHER
28	45757GS	1	HHCS, M6 - 1.0 x 25
29	706165	1	WIRE
30	797770	2	GASKET, Exhaust
31	84007593	1	MANIFOLD, Muffler
32	45771GS	2	NUT, M8 - 1.25
33	22237GS	2	WASHER, Locking, 3/8
34	84007592	1	MUFFLER
35	26850GS	1	WASHER, Ext. M6 - 1/4" Shakeproof
36	84001684	4	BOLT
37	84007309	1	HEATSHIELD, Rear
38	84007310	1	HEATSHIELD, End
39	772231	1	DECAL
40	43107GS	2	SCREW
41	REF-80012663	1	Refer to: Alternator Group
50	791745	1	LINE, Fuel -(Includes 2 Hose Clamps, Cut To Length)
51	209417GS	1	VALVE, Fuel
52	315017GS	1	HOSE, Vapor (cut to fit) -(Includes 1 Hose Clamp)
53	706376	1	COVER-RUBBER
54	706535	4	PAD-RUBBER
55	709931	4	NUT
56	791850	2	CLAMP, Hose
57	709935	2	SCREW
58	706150	1	WIRE

Footnotes:

Note:* (Verify your specific engine model, reference the ID Tag located on your engine.) (Refer to your local Briggs & Stratton distributor for parts and service.)

Main Unit

Note: Unless noted otherwise, use the standard torque specifications

030728-04- 6,250 Watt Storm Generator, Briggs & Stratton 49 State

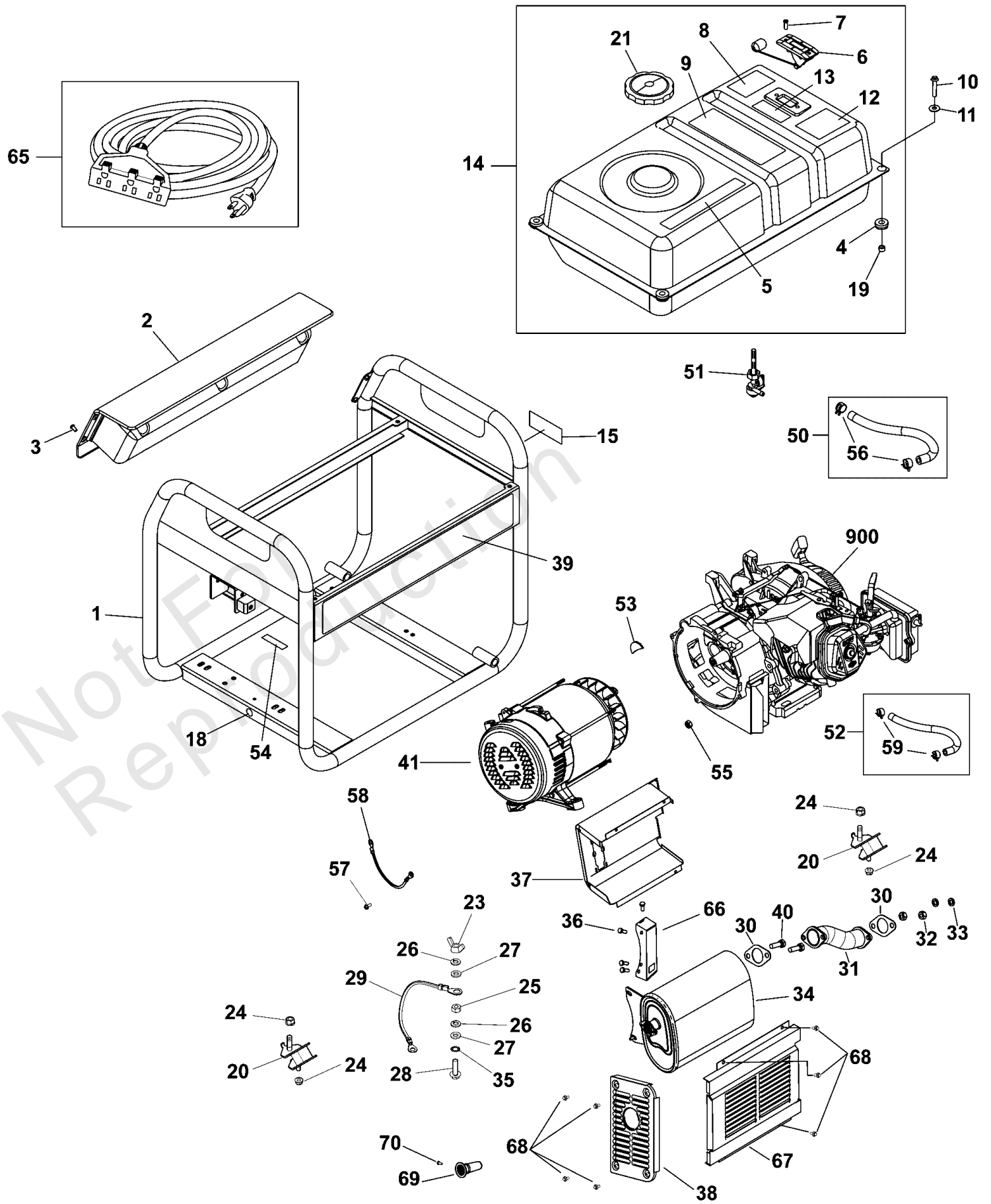

Main Unit

REF NO	PART NO	QTY	DESCRIPTION
59	314955GS	2	CLAMP
65	771800	1	CORDSET
66	84007363	1	BRACKET, Muffler
67	84007310	1	HEATSHIELD, End
68	706152	7	SCREW, M6 x 12
69	84007598	1	ARRESTOR, Spark
70	75475GS	1	SCREW
900	80005671		*ENGINE -*(Refer to Note:)

Not For
Reproduction

Footnotes:

Note:* (Verify your specific engine model, reference the ID Tag located on your engine.) (Refer to your local Briggs & Stratton distributor for parts and service.)

Wheel Kit

Note: Unless noted otherwise, use the standard torque specifications

030728-04- 6,250 Watt Storm Generator, Briggs & Stratton 49 State

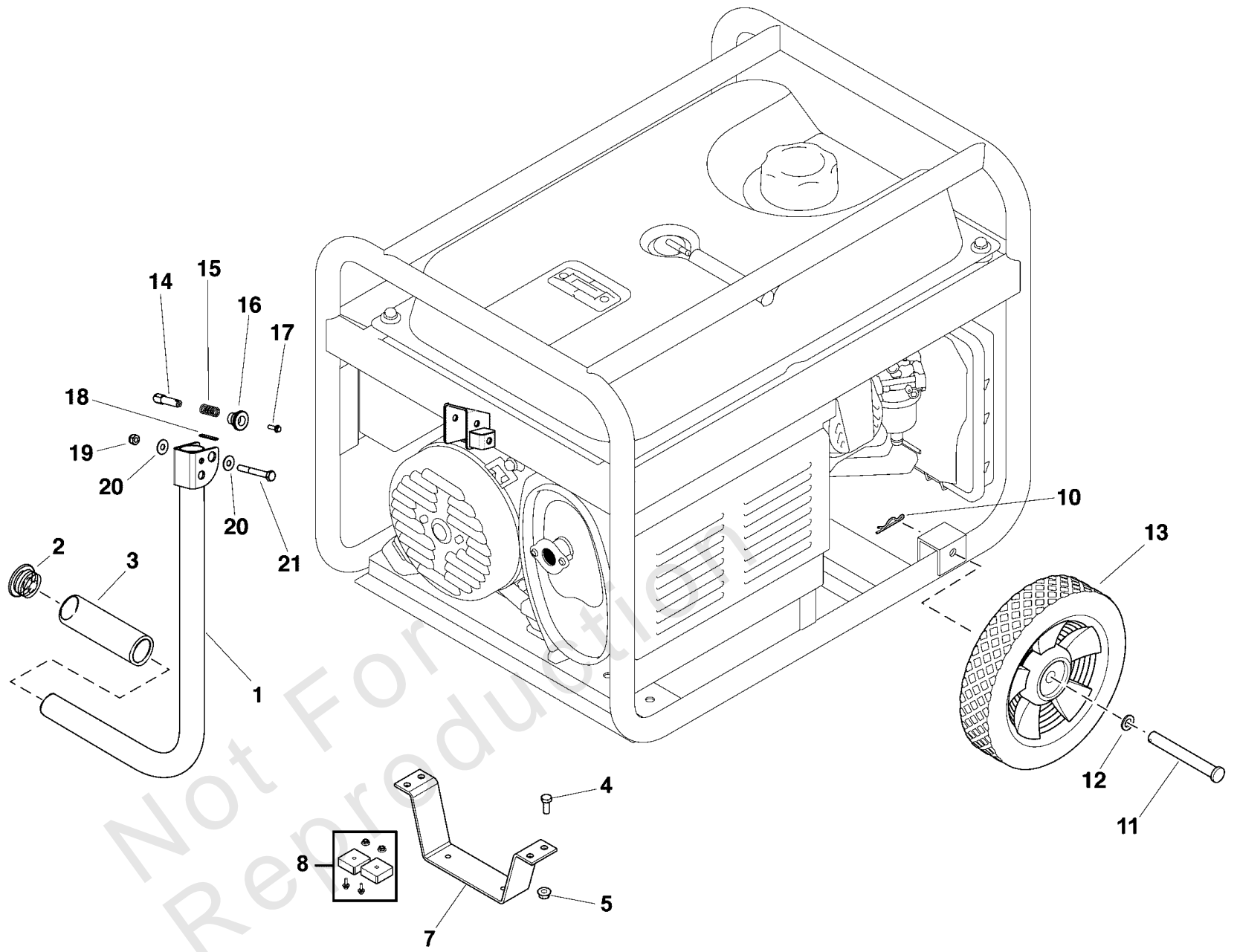

Wheel Kit

REF NO	PART NO	QTY	DESCRIPTION
1	84007312	1	HANDLE ASSY
2	84007314	1	PLUG, Handle
3	84007313	1	GRIP, Handle
4	771804	2	BOLT
5	67989GS	2	NUT, M8 Flange Serrated
7	84007497	1	SUPPORT LEG
8	319285GS	1	MOUNT-VIBRATION
10	316510GS	2	PIN-HAIR
11	84007496	2	AXLE-PIN
12	22247GS	2	WASHER, Flat, 5/8"
13	705935	2	WHEEL
14	319454GS	1	PIN
15	319452GS	1	SPRING
16	319453GS	1	KNOB
17	84001685	1	BOLT
18	84007344	1	PAD, Rubber Handle
19	49820GS	1	NUT, Nylok, M8 - 1.25
20	84007525	2	WASHER
21	51730GS	1	SCREW

Not For Reproduction

Wiring Diagram

Note: Unless noted otherwise, use the standard torque specifications

030728-04- 6,250 Watt Storm Generator, Briggs & Stratton 49 State

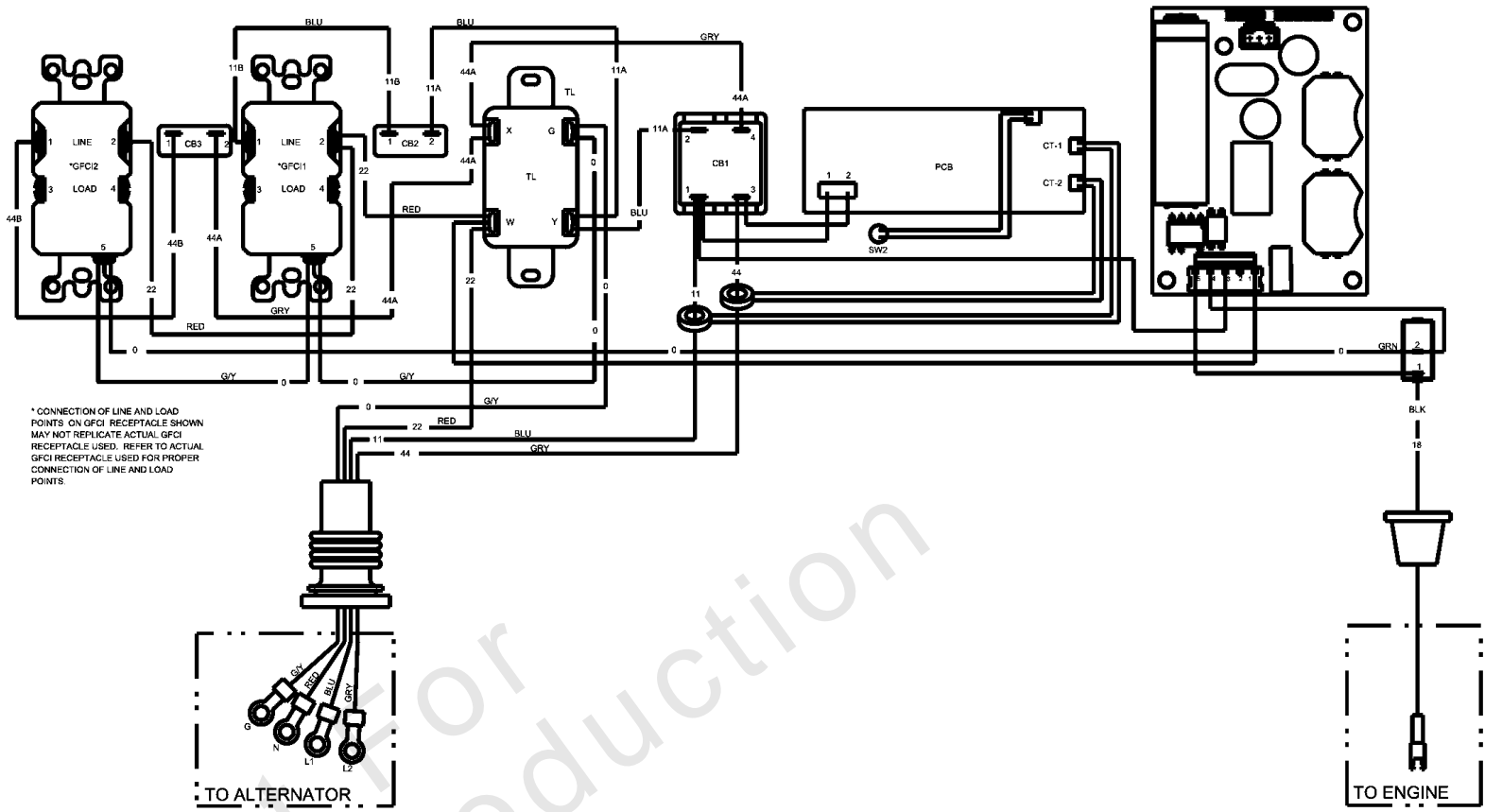
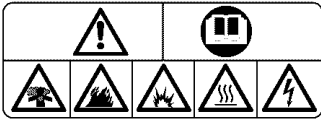

Wiring Diagram

REF NO	PART NO	QTY	DESCRIPTION
--	-----		Wiring Diagram Only
--	-----		WARNING - Generator Voltage Could Cause Electrical Shock or Burn Resulting in Death Or Serious Injury. To Avoid Electrical Shock Or Burn Hazard, Please Refer Service To Qualified Personnel.

Not For Reproduction

Wiring Schematic

Note: Unless noted otherwise, use the standard torque specifications

030728-04- 6,250 Watt Storm Generator, Briggs & Stratton 49 State

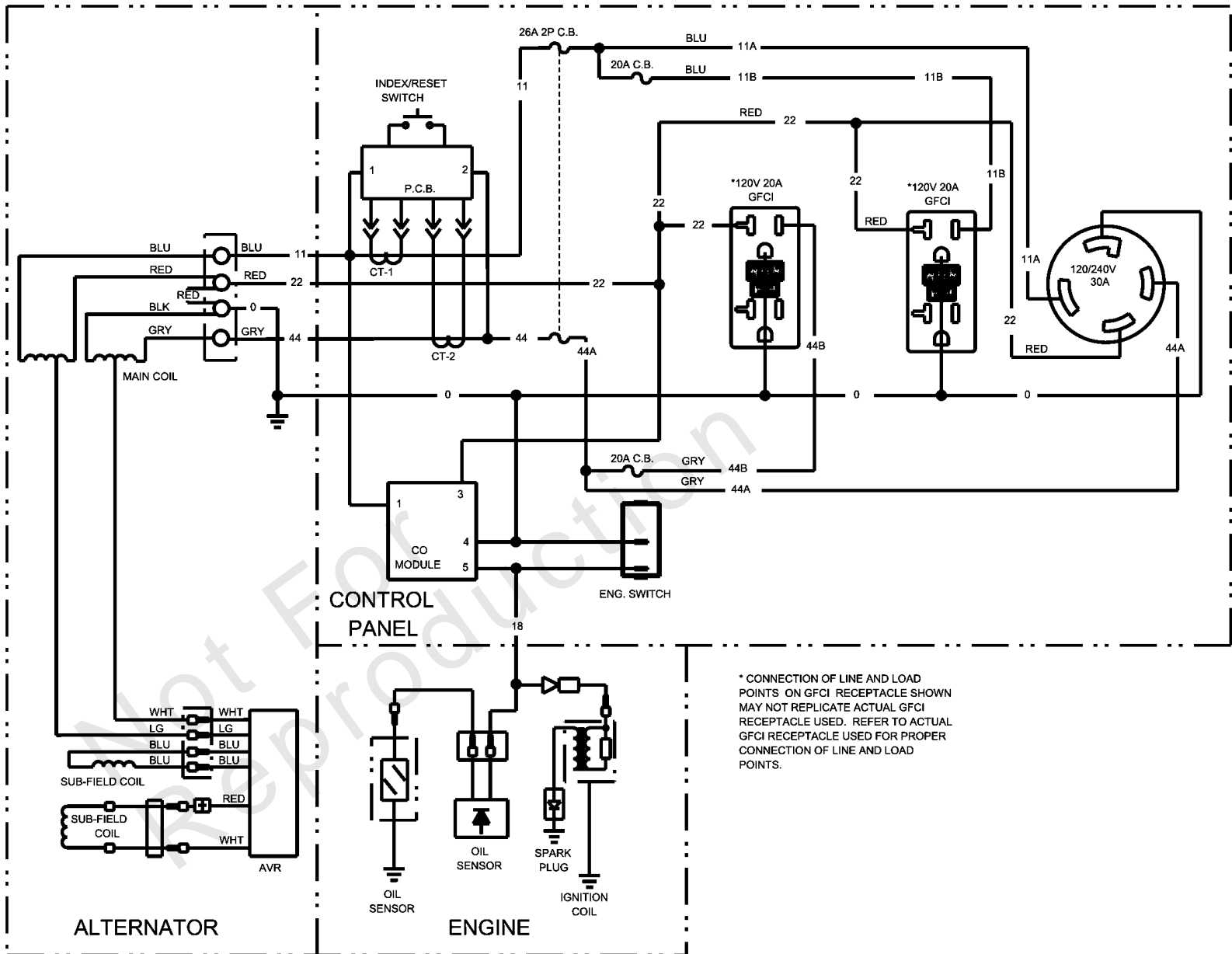
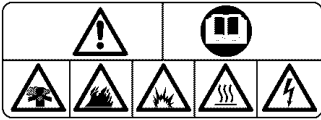

Wiring Schematic

REF NO	PART NO	QTY	DESCRIPTION
--	----		Wiring Schematic Only
--	----		WARNING - Generator Voltage Could Cause Electrical Shock or Burn Resulting in Death Or Serious Injury. To Avoid Electrical Shock Or Burn Hazard, Please Refer Service To Qualified Personnel.

Not For Reproduction

Hardware Identification & Torque Specifications

Torque Specification Chart								
FOR STANDARD METRIC MACHINE HARDWARE (Tolerance ± 20%)								
Property Class	5.6		8.8		10.9		12.9	
	Class 5.6		Class 8.8		Class 10.9		Class 12.9	
Size Of Hardware	in/lbs	Nm.	in/lbs	Nm.	in/lbs	Nm.	in/lbs	Nm.
	ft/lbs		ft/lbs		ft/lbs		ft/lbs	
M3	5.88	.56	13.44	1.28	19.2	1.80	22.92	2.15
M4	13.44	1.28	30.72	2.90	43.44	4.10	52.56	4.95
M5	26.4	2.50	60.96	5.75	5.97	8.10	7.15	9.7
M6	44.64	4.3	7.3	9.9	10.3	14	12.1	16.5
M7	5.2	7.1	12.1	16.5	16.9	23	19.9	27
M8	7.7	10.5	17.7	24	25	34	29	40
M10	15	21	35	48	50	67	59	81
M12	26	36	61	83	86.2	117	103	140
M14	42	58	101	132	136	185	162	220
M16	64	88	147	200	210	285	250	340
M18	89	121	202	275	287	390	346	470
M20	126	171	290	390	405	550	486	660
M22	169	230	390	530	559	745	656	890
M24	217	295	497	375	708	960	840	1140
M27	320	435	733	995	1032	1400	1239	1680
M30	435	590	995	1350	1401	1900	1681	2280
M33	590	800	1349	1830	1902	2580	2278	3090
M36	759	1030	1740	2360	2441	3310	2935	3980
M39	988	1340	2249	3050	3163	4290	3798	5150

Torque Specification Chart						
FOR STANDARD MACHINE HARDWARE (Tolerance ± 20%)						
Hardware Grade	No Marks		SAE Grade 5		SAE Grade 8	
	SAE Grade 2		SAE Grade 5		SAE Grade 8	
Size Of Hardware	in/lbs	Nm.	in/lbs	Nm.	in/lbs	Nm.
	ft/lbs		ft/lbs		ft/lbs	
8-32	19	2.1	30	3.4	41	4.6
8-36	20	2.3	31	3.5	43	4.9
10-24	27	3.1	43	4.9	60	6.8
10-32	31	3.5	49	5.5	68	7.7
1/4-20	66	7.6	8	10.9	12	16.3
1/4-28	76	8.6	10	13.6	14	19.0
5/16-18	11	15.0	17	23.1	25	34.0
5/16-24	12	16.3	19	25.8	29	34.0
3/8-16	20	27.2	30	40.8	45	61.2
3/8-24	23	31.3	35	47.6	50	68.0
7/16-14	30	40.8	50	68.0	70	95.2
7/16-20	35	47.6	55	74.8	80	108.8
1/2-13	50	68.0	75	102.0	110	149.6
1/2-20	55	74.8	90	122.4	120	163.2
9/16-12	65	88.4	110	149.6	150	204.0
9/16-18	75	102.0	120	163.2	170	231.2
5/8-11	90	122.4	150	204.0	220	299.2
5/8-18	100	136	180	244.8	240	326.4
3/4-10	160	217.6	260	353.6	386	525.0
3/4-16	180	244.8	300	408.0	420	571.2
7/8-9	140	190.4	400	544.0	600	816.0
7/8-14	155	210.8	440	598.4	660	897.6
1-8	220	299.2	580	788.8	900	1,244.0
1-12	240	326.4	640	870.4	1,000	1,360.0

The guides and ruler furnished below are designed to help you select the appropriate hardware.



Nut, M8

Thread Diameter (mm)

Inside Diameter (in) Threads per inch

Nut, 1/2-16



Screw, M8- 1.25 x 25

Thread Diameter (mm) Distance between threads (mm) Body Length (mm)

Body Diameter Threads per inch Body Length (in)

Screw, 1/2- 16 x 2



Standard Hardware Sizing

When a washer or nut is identified as 1/2" (M8), this is the *Nominal size*, meaning the *inside diameter* is 1/2 inch (8mm metric thread diameter); if a second number is present it represents the *threads per inch* (distance between threads).

When bolt or capscrew is identified as 1/2 - 16 x 2" (M8 - 1.25 x 50), this means the *Nominal size*, or body diameter is 1/2 inch (8mm metric thread diameter), the second number, 16, represents the *threads per inch*, (*distance between threads*). The final number is the body length of the bolt or screw, 2 inches (50mm).

NOTES

- These torque values are to be used for all hardware excluding: locknuts, self-tapping screws, thread forming screws, sheet metal screws and socket head setscrews.
- Recommended seating torque values for locknuts:
 - for prevailing torque locknuts - use 65% of grade 5 torques.
 - for flange whizlock nuts and screws - use 135% of grade 5 torques.
- Unless otherwise noted on assembly drawings, all torque values must meet this specification.

Common Hardware Types

Hex Head Capscrew

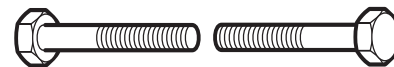

Washer



Carriage Bolt

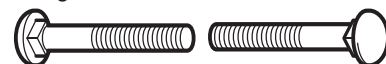

Hex Nut

Wrench & Fastener Size Guide

1/4" Bolt or Nut Wrench—7/16"	5/16" Bolt or Nut Wrench—1/2"	3/8" Bolt or Nut Wrench—9/16"	7/16" Bolt or Nut Wrench (Bolt)—5/8" Wrench (Nut)—11/16"	1/2" Bolt or Nut Wrench—3/4"
M6 Bolt or Nut Wrench—10mm	M8 Bolt or Nut Wrench—13mm	M10 Bolt or Nut Wrench—17mm	M12 Bolt or Nut Wrench—19mm	M14 Bolt or Nut Wrench—22mm

