

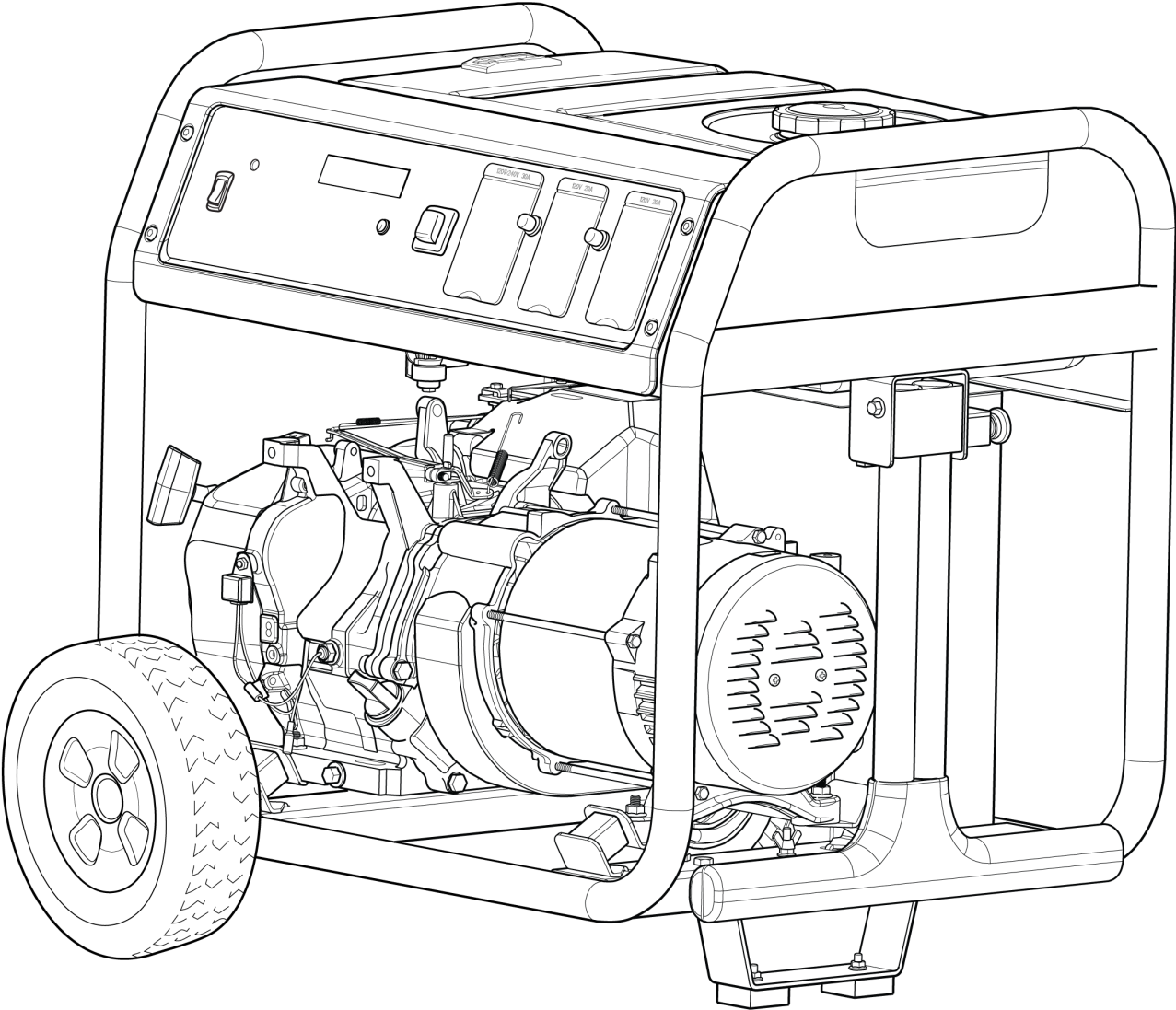

Parts Manual

Watt Storm Generator, Briggs & Stratton 49 State



Model Components	Page
Control Panel.....	4
Main Unit.....	6
Wheel Kit (80005137).....	10
Wiring Diagram.....	12
Wiring Schematic.....	14
Torque Specification Chart.....	16

Not For
Reproduction

Control Panel

Note: Unless noted otherwise, use the standard torque specifications

030728-01- 6,250 Watt Storm Generator, Briggs & Stratton 49 State

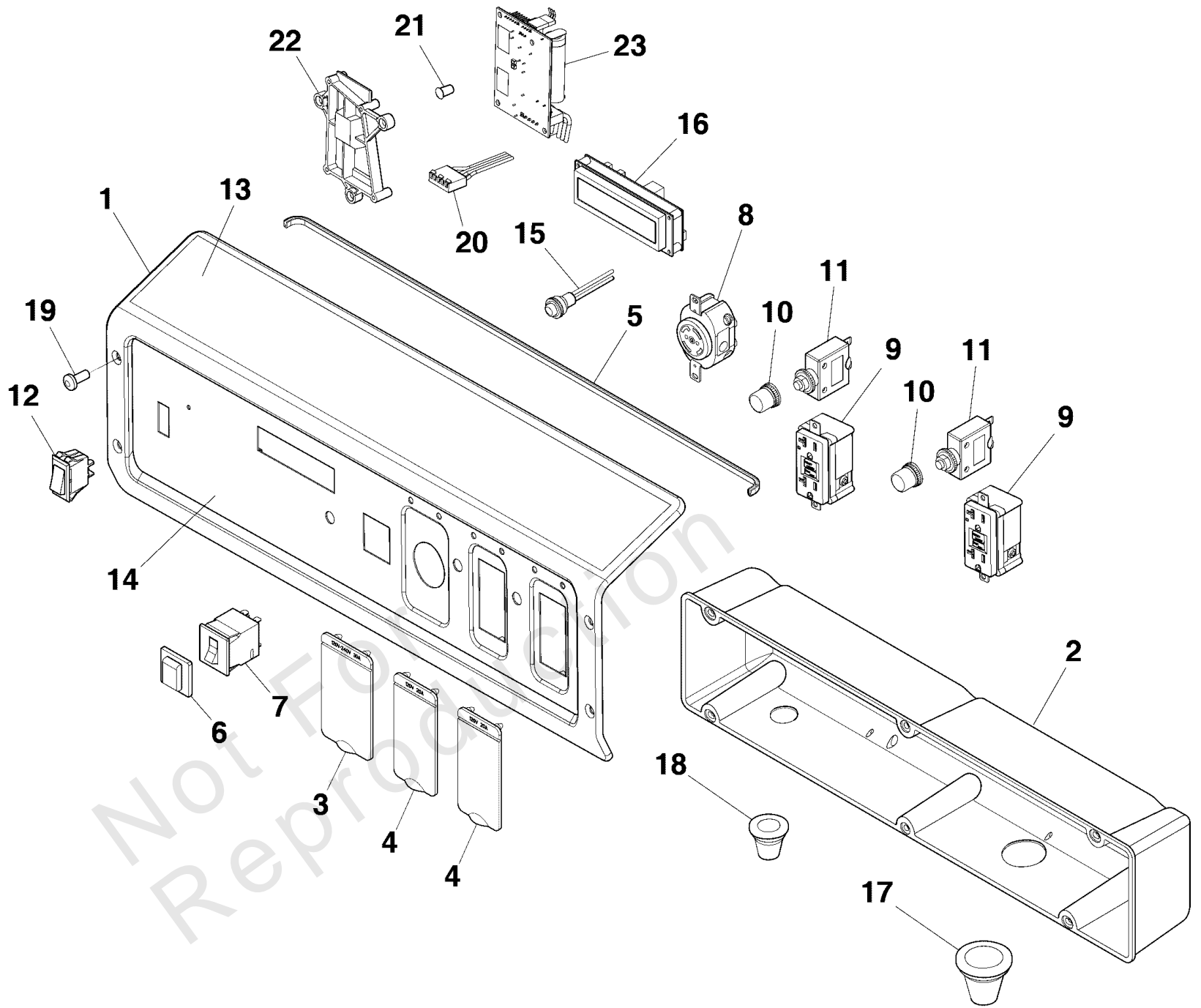

Control Panel

REF NO	PART NO	QTY	DESCRIPTION
1	772210		PANEL-CONTROL -(Includes Item 13 & 14)
2	772214		BOX-CONTROL-PANEL
3	319477GS		COVER-OUTLET
4	319476GS		COVER-OUTLET
5	319459GS		TRIM-EDGE
6	191481GS		BOOT, Breaker Circuit
7	319540GS		BREAKER-CIRCUIT
8	43437GS		OUTLET, 120/240V Locking, 30A
9	709526		OUTLET-GFCI
10	312636GS		BOOT, Circuit Breaker
11	209872GS		BREAKER-CIRCUIT 20A
12	319525GS		SWITCH-ON/OFF
13	772212		DECAL
14	772216		DECAL
15	319463GS		BUTTON-SELECT
16	318458GS		POWER MONITOR
17	319529GS		GROMMET
18	319530GS		GROMMET
19	772229		SCREW
20	772215		WIRE-HARNESS-CO
21	772217		LIGHT-PIPE
22	772213		BRACKET-MODULE
23	772211		MODULE-CO

Main Unit

Note: Unless noted otherwise, use the standard torque specifications

030728-01- 6,250 Watt Storm Generator, Briggs & Stratton 49 State

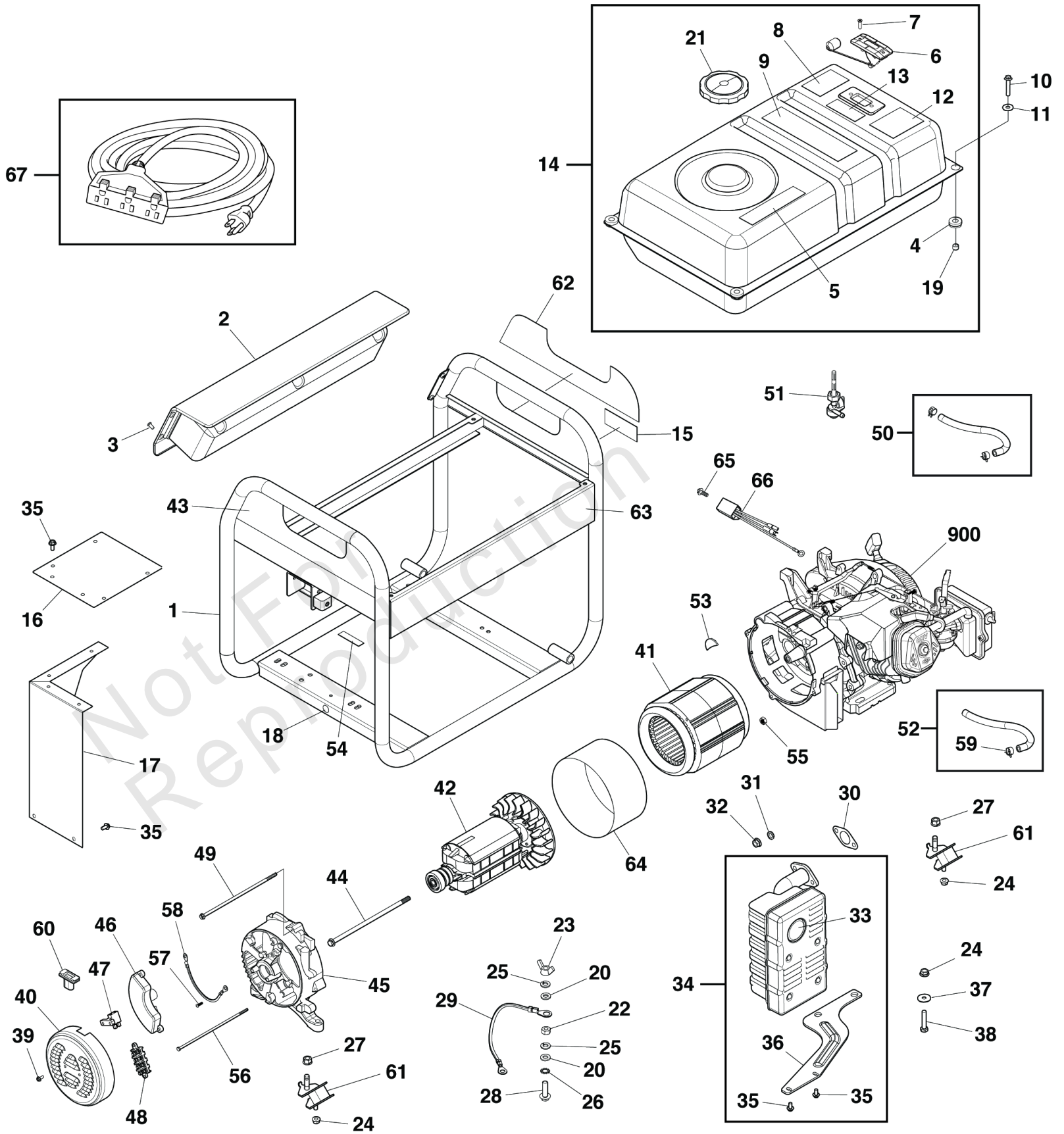

Main Unit

REF NO	PART NO	QTY	DESCRIPTION
1	772226	1	CRADLE -(Includes Item 15, 18 & 63)
2	772230	1	PANEL-CONTROL
3	772229	4	SCREW
4	189134GS	4	GROMMET, Rubber
5	772237	1	DECAL
6	704183	1	GAUGE-FUEL
7	314440GS	2	SCREW
8	772233	1	DECAL
9	772234	1	DECAL
10	703805	4	SCREW
11	312005GS	4	WASHER
12	202997GS	1	DECAL, Warning, CO
13	703264	1	DECAL
14	772227	1	TANK-FUEL
15	772236	1	DECAL
16	319456GS	1	HEATSHIELD
17	319455GS	1	HEATSHIELD
18	704331	1	DECAL
19	189137GS	4	SPACER
20	-----	2	WASHER, Flat M6
21	319587GS	1	CAP-FUEL
22	-----	1	NUT, Hex, M6
23	87680GS	1	NUT, M6 - 1.0 Wing
24	-----	4	* NUT, Flange Lock, M8
25	-----	2	* WASHER, Lock, M6
26	-----	1	* WASHER, Shakeproof, Ext M6
27	-----	4	* NUT, Flange Lock, M10
28	-----	1	HHCS, M6 - 1.0 x 25
29	706165	1	WIRE
30	813085GS	1	GASKET
31	-----	2	* WASHER, Lock, M8
32	-----	2	* NUT, Hex, M8-1.25
33	83083GS	1	SCREEN, Spark Arrest
34	84003865	1	KIT-MUFFLER
35	706152	8	SCREW, M6 x 12
36	319457GS	1	BRACKET, Muffler
37	-----	1	* WASHER, Flat M8
38	57821GS	1	CAPSCREW, Hex Head, M8-1.25 x 40
39	312909GS	2	SCREW
40	312870GS	1	COVER, Rear Bearing
41	706903	1	STATOR
42	706902	1	ROTOR
43	772232	1	DECAL
44	703910	1	BOLT
45	312866GS	1	SUPPORT, Bearing
46	312871GS	1	REGULATOR-VOLTAGE
47	312904GS	1	BRUSH ASSEMBLY

Footnotes:

(Note:* Verify your specific engine model, reference the ID Tag located on your engine.) (Refer to your local Briggs & Stratton distributor for parts and service.)
* Items without part numbers are common fasteners and are available at your local hardware store.

Main Unit

Note: Unless noted otherwise, use the standard torque specifications

030728-01- 6,250 Watt Storm Generator, Briggs & Stratton 49 State

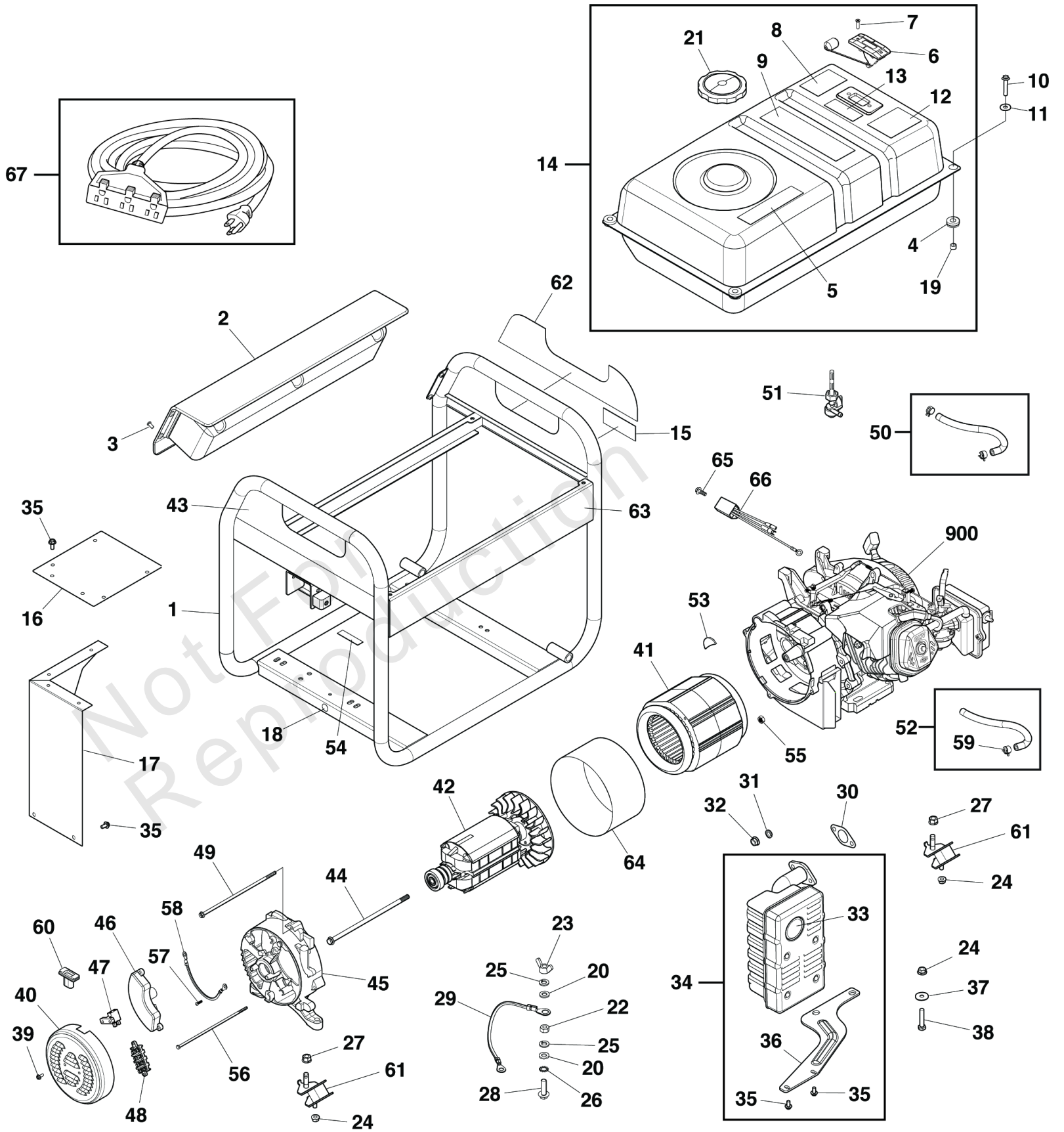

Main Unit

REF NO	PART NO	QTY	DESCRIPTION
48	312921GS	1	BLOCK, Junction
49	703909	1	BOLT
50	791745	1	LINE, Fuel -(Cut to Fit)
51	209417GS	1	VALVE, Fuel
52	315017GS	1	HOSE, Vapor (cut to fit)
53	706376	1	COVER-RUBBER
54	706535	1	PAD-RUBBER
55	312916GS	3	NUT
56	703908	1	BOLT
57	312911GS	2	SCREW
58	706150	1	WIRE
59	314955GS	2	CLAMP
60	703013	1	COVER, Alternator, Rubber
61	319451GS	4	MOUNT-VIBRATION
62	772228	1	DECAL
63	772231	1	DECAL
64	703911	1	BAND-STATOR
65	84003179	1	SCREW
66	84003180	1	MODULE-SNUBBER
67	771800	1	CORDSET
900	25P132-0006-G1	1	ENGINE

Footnotes:

(Note:* Verify your specific engine model, reference the ID Tag located on your engine.) (Refer to your local Briggs & Stratton distributor for parts and service.)

* Items without part numbers are common fasteners and are available at your local hardware store.

Wheel Kit (80005137)

Note: Unless noted otherwise, use the standard torque specifications

030728-01- 6,250 Watt Storm Generator, Briggs & Stratton 49 State

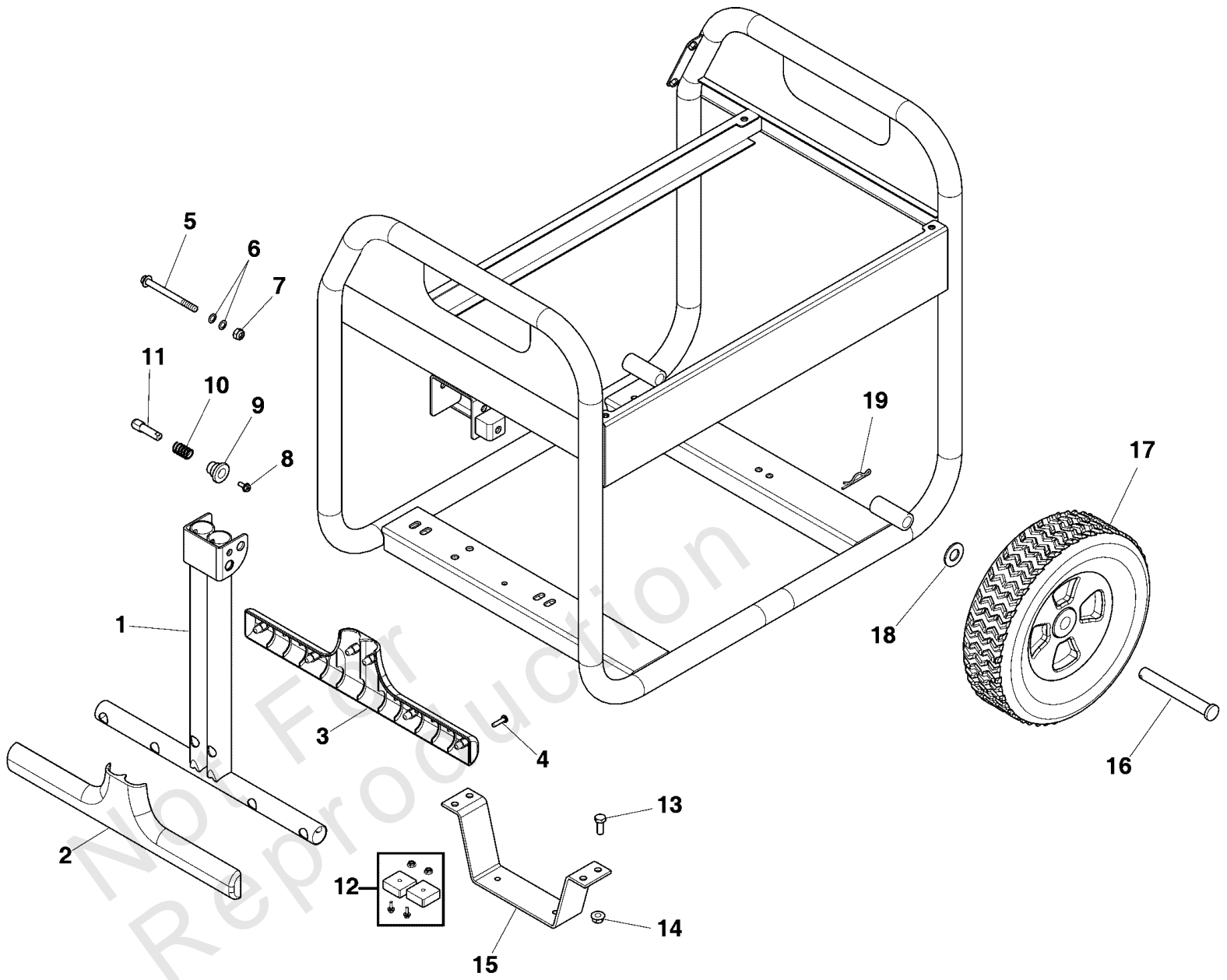

Wheel Kit (80005137)

REF NO	PART NO	QTY	DESCRIPTION
1	319396GS	1	HANDLE
2	319360GS	1	GRIP-HANDLE
3	319361GS	1	GRIP-HANDLE
4	75477GS	1	PPHMS, M5 - 0.8 x 20
5	318677GS	1	BOLT
6	96716GS	1	WASHER, Nylon
7	49820GS	1	NUT, Nylok, M8 - 1.25
8	207825GS	1	BOLT-M5-6 x 16
9	319453GS	1	KNOB
10	319452GS	1	SPRING
11	319454GS	1	PIN
12	319285GS	1	MOUNT-VIBRATION
13	771804	1	BOLT
14	67989GS	1	NUT, M8 Flange Serrated
15	319642GS	1	SUPPORT-LEG
16	703813	1	AXLE
17	704145	1	WHEEL
18	22247GS	1	WASHER, Flat, 5/8"
19	316510GS	1	PIN-HAIR

Not For Reproduction

Wiring Diagram

Note: Unless noted otherwise, use the standard torque specifications

030728-01- 6,250 Watt Storm Generator, Briggs & Stratton 49 State

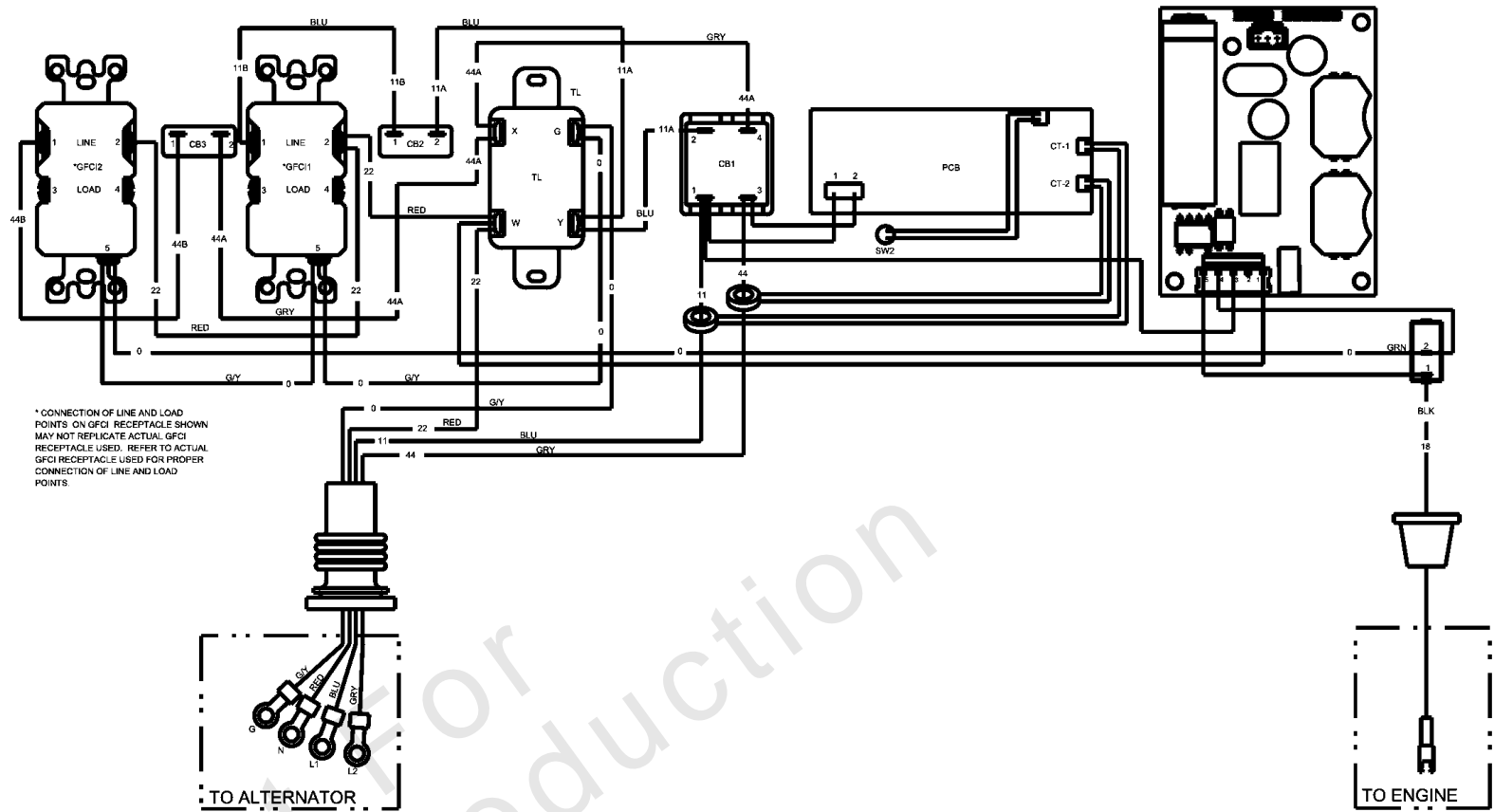
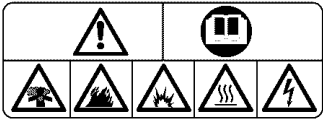

Wiring Diagram

REF NO	PART NO	QTY	DESCRIPTION
--	-----		Wiring Diagram Only
--	-----		WARNING - Generator Voltage Could Cause Electrical Shock or Burn Resulting in Death Or Serious Injury. To Avoid Electrical Shock Or Burn Hazard, Please Refer Service To Qualified Personnel.

Not For Reproduction

Wiring Schematic

Note: Unless noted otherwise, use the standard torque specifications

030728-01- 6,250 Watt Storm Generator, Briggs & Stratton 49 State

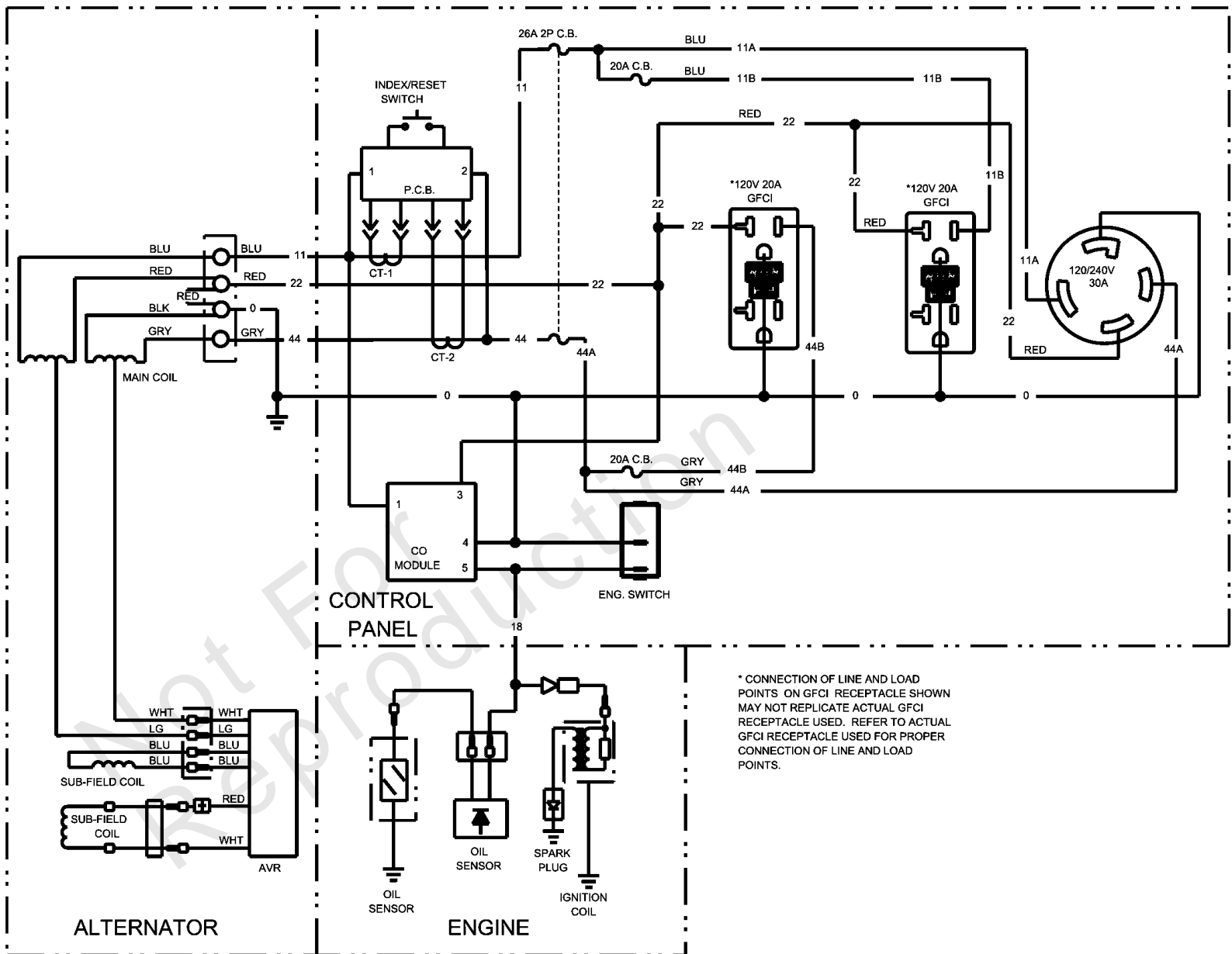
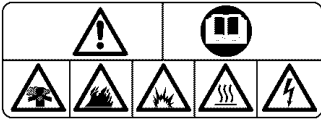

Wiring Schematic

REF NO	PART NO	QTY	DESCRIPTION
--	----		Wiring Schematic Only
--	----		WARNING - Generator Voltage Could Cause Electrical Shock or Burn Resulting in Death Or Serious Injury. To Avoid Electrical Shock Or Burn Hazard, Please Refer Service To Qualified Personnel.

Not For Reproduction

Hardware Identification & Torque Specifications

Torque Specification Chart								
FOR STANDARD METRIC MACHINE HARDWARE (Tolerance ± 20%)								
Property Class	5.6		8.8		10.9		12.9	
	Class 5.6		Class 8.8		Class 10.9		Class 12.9	
Size Of Hardware	in/lbs	Nm.	in/lbs	Nm.	in/lbs	Nm.	in/lbs	Nm.
	ft/lbs		ft/lbs		ft/lbs		ft/lbs	
M3	5.88	.56	13.44	1.28	19.2	1.80	22.92	2.15
M4	13.44	1.28	30.72	2.90	43.44	4.10	52.56	4.95
M5	26.4	2.50	60.96	5.75	5.97	8.10	7.15	9.7
M6	44.64	4.3	7.3	9.9	10.3	14	12.1	16.5
M7	5.2	7.1	12.1	16.5	16.9	23	19.9	27
M8	7.7	10.5	17.7	24	25	34	29	40
M10	15	21	35	48	50	67	59	81
M12	26	36	61	83	86.2	117	103	140
M14	42	58	101	132	136	185	162	220
M16	64	88	147	200	210	285	250	340
M18	89	121	202	275	287	390	346	470
M20	126	171	290	390	405	550	486	660
M22	169	230	390	530	559	745	656	890
M24	217	295	497	375	708	960	840	1140
M27	320	435	733	995	1032	1400	1239	1680
M30	435	590	995	1350	1401	1900	1681	2280
M33	590	800	1349	1830	1902	2580	2278	3090
M36	759	1030	1740	2360	2441	3310	2935	3980
M39	988	1340	2249	3050	3163	4290	3798	5150

Torque Specification Chart						
FOR STANDARD MACHINE HARDWARE (Tolerance ± 20%)						
Hardware Grade	No Marks		SAE Grade 5		SAE Grade 8	
	SAE Grade 2		SAE Grade 5		SAE Grade 8	
Size Of Hardware	in/lbs	Nm.	in/lbs	Nm.	in/lbs	Nm.
	ft/lbs		ft/lbs		ft/lbs	
8-32	19	2.1	30	3.4	41	4.6
8-36	20	2.3	31	3.5	43	4.9
10-24	27	3.1	43	4.9	60	6.8
10-32	31	3.5	49	5.5	68	7.7
1/4-20	66	7.6	8	10.9	12	16.3
1/4-28	76	8.6	10	13.6	14	19.0
5/16-18	11	15.0	17	23.1	25	34.0
5/16-24	12	16.3	19	25.8	29	34.0
3/8-16	20	27.2	30	40.8	45	61.2
3/8-24	23	31.3	35	47.6	50	68.0
7/16-14	30	40.8	50	68.0	70	95.2
7/16-20	35	47.6	55	74.8	80	108.8
1/2-13	50	68.0	75	102.0	110	149.6
1/2-20	55	74.8	90	122.4	120	163.2
9/16-12	65	88.4	110	149.6	150	204.0
9/16-18	75	102.0	120	163.2	170	231.2
5/8-11	90	122.4	150	204.0	220	299.2
5/8-18	100	136	180	244.8	240	326.4
3/4-10	160	217.6	260	353.6	386	525.0
3/4-16	180	244.8	300	408.0	420	571.2
7/8-9	140	190.4	400	544.0	600	816.0
7/8-14	155	210.8	440	598.4	660	897.6
1-8	220	299.2	580	788.8	900	1,244.0
1-12	240	326.4	640	870.4	1,000	1,360.0

The guides and ruler furnished below are designed to help you select the appropriate hardware.



Nut, M8

Thread Diameter (mm)

Inside Diameter (in) Threads per inch

Nut, 1/2-16



Screw, M8- 1.25 x 25

Thread Diameter (mm) Distance between threads (mm) Body Length (mm)

Body Diameter Threads per inch Body Length (in)

Screw, 1/2- 16 x 2



Standard Hardware Sizing

When a washer or nut is identified as 1/2" (M8), this is the *Nominal size*, meaning the *inside diameter* is 1/2 inch (8mm metric thread diameter); if a second number is present it represents the *threads per inch* (distance between threads).

When bolt or capscrew is identified as 1/2 - 16 x 2" (M8 - 1.25 x 50), this means the *Nominal size*, or body diameter is 1/2 inch (8mm metric thread diameter), the second number, 16, represents the *threads per inch*, (*distance between threads*). The final number is the body length of the bolt or screw, 2 inches (50mm).

NOTES

- These torque values are to be used for all hardware excluding: locknuts, self-tapping screws, thread forming screws, sheet metal screws and socket head setscrews.
- Recommended seating torque values for locknuts:
 - for prevailing torque locknuts - use 65% of grade 5 torques.
 - for flange whizlock nuts and screws - use 135% of grade 5 torques.
- Unless otherwise noted on assembly drawings, all torque values must meet this specification.

Common Hardware Types

Hex Head Capscrew



Washer



Carriage Bolt



Hex Nut

Wrench & Fastener Size Guide

1/4" Bolt or Nut Wrench—7/16"	5/16" Bolt or Nut Wrench—1/2"	3/8" Bolt or Nut Wrench—9/16"	7/16" Bolt or Nut Wrench (Bolt)—5/8" Wrench (Nut)—11/16"	1/2" Bolt or Nut Wrench—3/4"
M6 Bolt or Nut Wrench—10mm	M8 Bolt or Nut Wrench—13mm	M10 Bolt or Nut Wrench—17mm	M12 Bolt or Nut Wrench—19mm	M14 Bolt or Nut Wrench—22mm

