

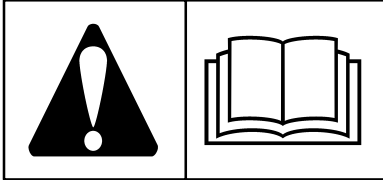



**Classic™ /Sprint™ /Quattro™
Model Series 90000, 100000**



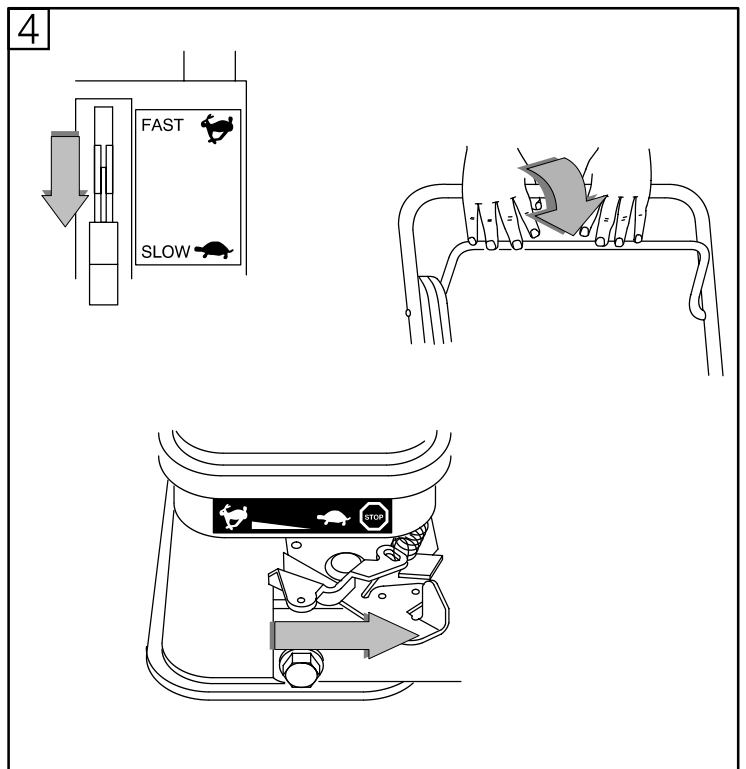
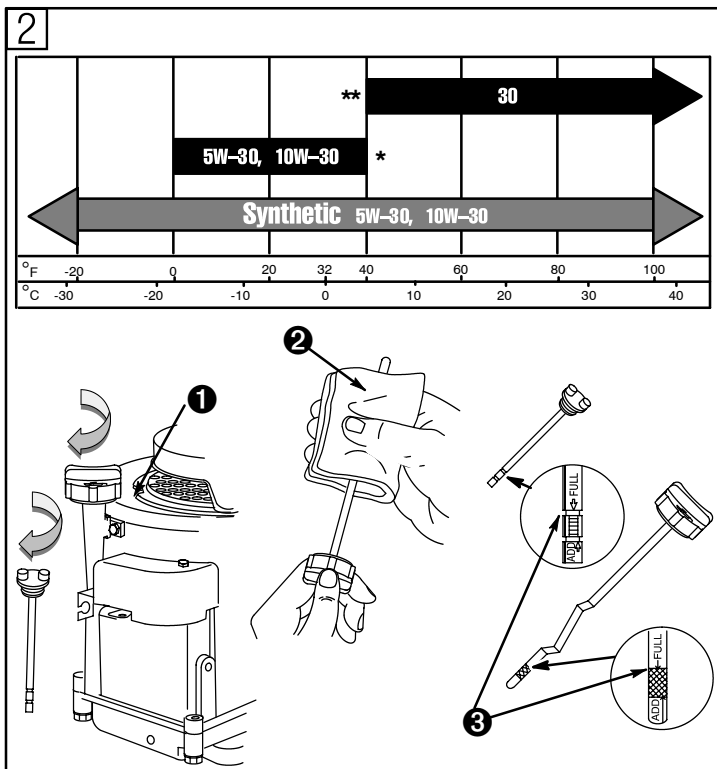
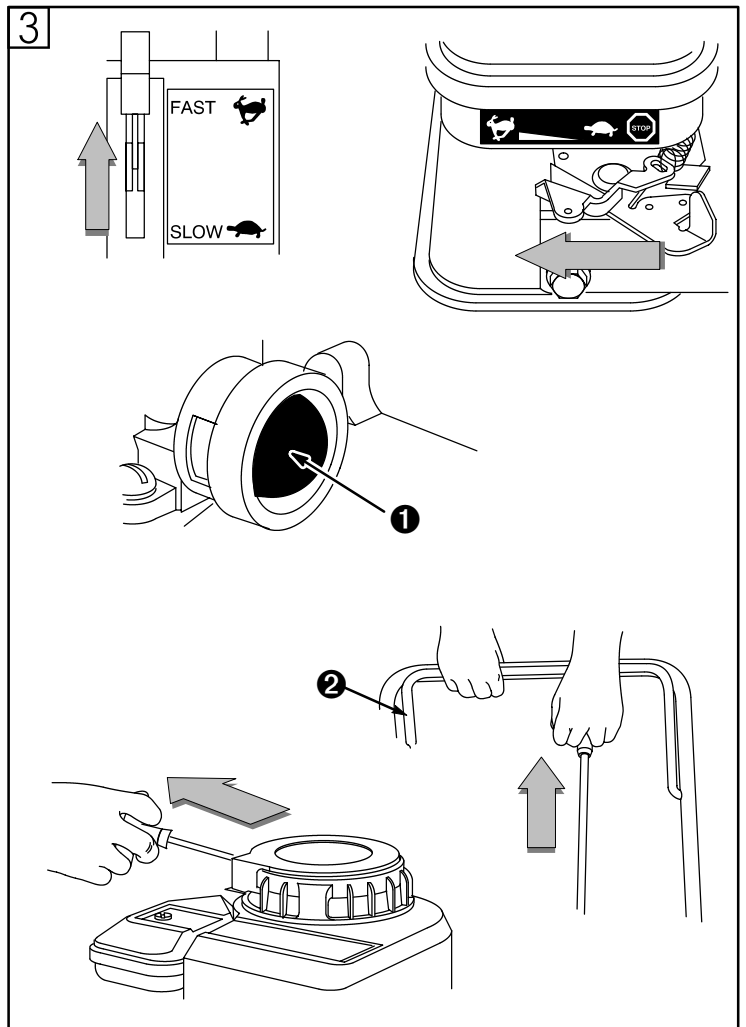
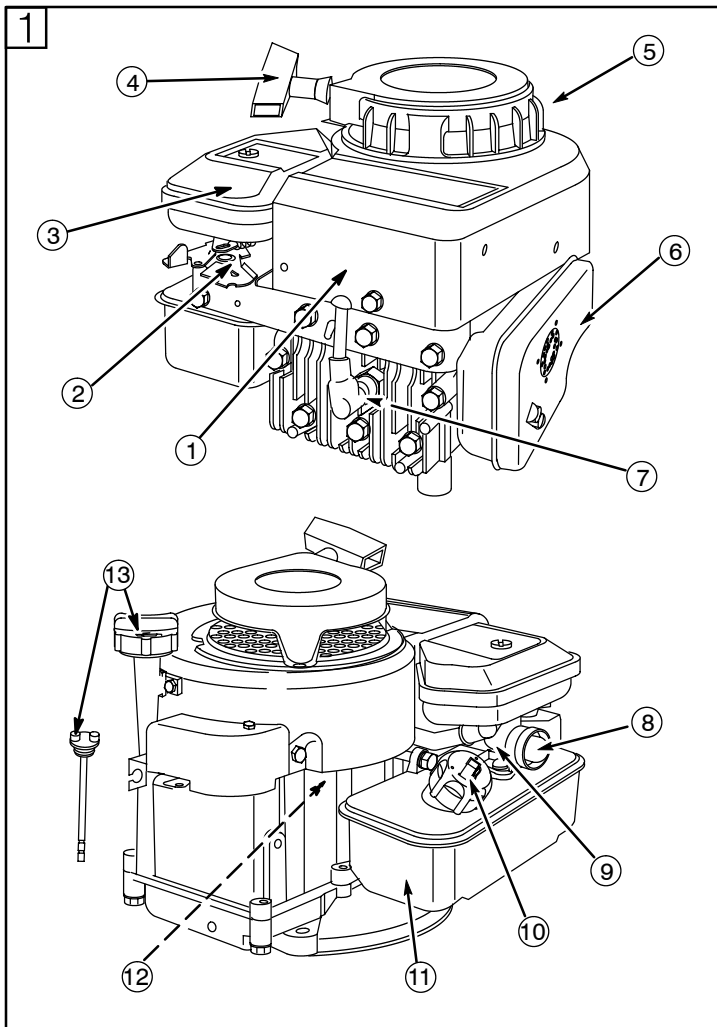

- (GB) *Operating & Maintenance Instructions***
- (D) *Betriebsanleitung & Wartungsvorschriften***
- (DK) *Drifts- og vedligeholdelsesvejledning***
- (E) *Instrucciones de Mantenimiento & Operación***
- (F) *Instructions d'utilisation et de maintenance***
- (GR) *Ίαçãßàò Èáéôïñãßàò & Óóïôñçóçò***
- (I) *Istruzioni per l'uso e la manutenzione***
- (N) *Anvisninger for bruk og vedlikehold***
- (NL) *Gebruiksaanwijzing***
- (P) *Instruções de operação e de manutenção***
- (S) *Instruktionsbok***
- (SF) *Käyttö & Huolto-ohjeet***









Note: (This note applies only to engines used in the U.S.A.) Maintenance, replacement or repair of the emission control devices and systems may be performed by any nonroad engine repair establishment or individual. However, to obtain no charge repairs under the terms and provisions of the Briggs & Stratton warranty statement, any service or emission control part repair or replacement must be performed by a factory authorized dealer. 

How To Use Manual Figures

 -  refer to figures inside covers.

 -  refer to engine components in figure .

 -  refer to part/action in figures.













Record your engine Model, Type and Code numbers here for future use.

Record your date of purchase here for future use.

Technical Information

POWER RATINGS: The power ratings for an individual engine model are initially developed by starting with SAE (Society of Automotive Engineers) code J1940 (Small Engine Power & Torque Rating Procedure) (Revision 2002-05). Given both the wide array of products on which our engines are placed, and the variety of environmental issues applicable to operating the equipment, it may be that the engine you have purchased will not develop the rated horsepower when used in a piece of power equipment (actual "on-site" power). This difference is due to a variety of factors including, but not limited to, the following: differences in altitude, temperature, barometric pressure, humidity, fuel, engine lubrication, maximum governed engine speed, individual engine to engine variability, design of the particular piece of power equipment, the manner in which the engine is operated, engine run-in to reduce friction and clean out of combustion chambers, adjustments to the valves and carburetor, and other factors. The power ratings may also be adjusted based on comparisons to other similar engines utilized in similar applications, and will therefore not necessarily match the values derived using the foregoing codes.

Engine Components (see fig.)

- |  Engine | Model
xxxxxx | Type
xxxx xx | Code
xxxxxxx |
|---|-----------------|-----------------|-----------------|
|  Governor control lever | | | |
|  Air cleaner | | | |
|  Rope handle | | | |
|  Finger guard | | | |
|  Muffler/spark arrester, if equipped | | | |
|  Spark plug | | | |
|  Primer bulb | | | |
|  Carburetor | | | |
|  Fuel fill | | | |
|  Fuel tank | | | |
|  Flywheel | | | |
|  Oil fill/Dipstick | | | |

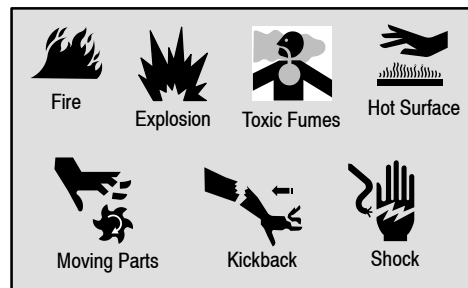

Hazard Symbols and Meanings

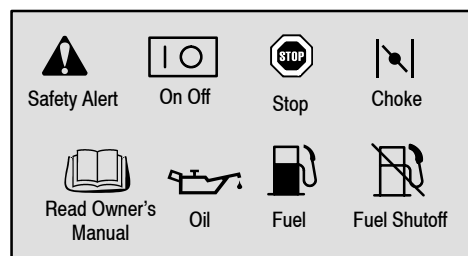

International Symbols and Meanings



Safety Precautions

  **BEFORE OPERATING ENGINE**

- Read entire Operating & Maintenance Instructions AND the instructions for the equipment this engine powers.*
- Failure to follow instructions could result in serious injury or death.

* Briggs & Stratton does not necessarily know what equipment this engine will power. For that reason, you should carefully read and understand the operating instructions for the equipment on which your engine is placed.

THE OPERATING & MAINTENANCE INSTRUCTIONS CONTAIN SAFETY INFORMATION TO

- Make you aware of hazards associated with engines
- Inform you of the risk of injury associated with those hazards, and
- Tell you how to avoid or reduce the risk of injury.

 The safety alert symbol is used to identify safety information about hazards that can result in personal injury.



A signal word (DANGER, WARNING, or CAUTION) is used with the alert symbol to indicate the likelihood and the potential severity of injury. In addition, a hazard symbol may be used to represent the type of hazard.

 **DANGER** indicates a hazard which, if not avoided, will result in death or serious injury.



 **WARNING** indicates a hazard which, if not avoided, could result in death or serious injury.



 **CAUTION** indicates a hazard which, if not avoided, might result in minor or moderate injury.



CAUTION, when used **without** the alert symbol, indicates a situation that **could result in damage to the engine**.



 **WARNING** 

The engine exhaust from this product contains chemicals known to the State of California to cause cancer, birth defects, or other reproductive harm.

 WARNING

<p>Gasoline and its vapors are extremely flammable and explosive.</p> <p>Fire or explosion can cause severe burns or death.</p>
<p>WHEN ADDING FUEL</p> <ul style="list-style-type: none"> • Turn engine OFF and let engine cool at least 2 minutes before removing gas cap. • Fill fuel tank outdoors or in well-ventilated area. • Do not overfill fuel tank. Fill tank to approximately 1 inch below lowest portion of neck to allow for fuel expansion. • Keep gasoline away from sparks, open flames, pilot lights, heat, and other ignition sources. • Check fuel lines, tank, cap, and fittings frequently for cracks or leaks. Replace if necessary. <p>WHEN STARTING ENGINE</p> <ul style="list-style-type: none"> • Make sure spark plug, muffler, fuel cap and air cleaner are in place. • Do not crank engine with spark plug removed. • If fuel spills, wait until it evaporates before starting engine. • If engine floods, set choke to OPEN/RUN position, place throttle in FAST and crank until engine starts. <p>WHEN OPERATING EQUIPMENT</p> <ul style="list-style-type: none"> • Do not tip engine or equipment at angle which causes gasoline to spill. • Do not choke carburetor to stop engine. <p>WHEN TRANSPORTING EQUIPMENT</p> <ul style="list-style-type: none"> • Transport with fuel tank EMPTY or with fuel shut-off valve OFF. <p>WHEN STORING GASOLINE OR EQUIPMENT WITH FUEL IN TANK</p> <ul style="list-style-type: none"> • Store away from furnaces, stoves, water heaters or other appliances that have pilot light or other ignition source because they can ignite gasoline vapors.



 WARNING

<p>Engines give off carbon monoxide, an odorless, colorless, poison gas.</p> <p>Breathing carbon monoxide can cause nausea, fainting or death.</p>
<ul style="list-style-type: none"> • Start and run engine outdoors. • Do not start or run engine in enclosed area, even if doors or windows are open.



 WARNING

<p>Unintentional sparking can result in fire or electric shock.</p> <p>Unintentional start-up can result in entanglement, traumatic amputation, or laceration.</p>
<p>BEFORE PERFORMING ADJUSTMENTS OR REPAIRS</p> <ul style="list-style-type: none"> • Disconnect spark plug wire and keep it away from spark plug. • Disconnect battery at negative terminal (only engines with electric start). <p>WHEN TESTING FOR SPARK</p> <ul style="list-style-type: none"> • Use approved spark plug tester. • Do not check for spark with spark plug removed.

 WARNING

<p>Running engines produce heat. Engine parts, especially muffler, become extremely hot.</p> <p>Severe thermal burns can occur on contact.</p> <p>Combustible debris, such as leaves, grass, brush, etc. can catch fire.</p>
<ul style="list-style-type: none"> • Allow muffler, engine cylinder and fins to cool before touching. • Remove accumulated combustibles from muffler area and cylinder area. • Install and maintain in working order a spark arrester before using equipment on forest-covered, grass-covered, brush-covered unimproved land. The state of California requires this (Section 4442 of the California Public Resources Code). Other states may have similar laws. Federal laws apply on federal land.

 WARNING

<p>Rotating parts can contact or entangle hands, feet, hair, clothing, or accessories.</p> <p>Traumatic amputation or severe laceration can result.</p>
<ul style="list-style-type: none"> • Operate equipment with guards in place. • Keep hands and feet away from rotating parts. • Tie up long hair and remove jewelry. • Do not wear loose-fitting clothing, dangling drawstrings or items that could become caught.

 WARNING

<p>Starting engine creates sparking.</p> <p>Sparking can ignite nearby flammable gases.</p> <p>Explosion and fire could result.</p>
<ul style="list-style-type: none"> • If there is natural or LP gas leakage in area, do not start engine. • Do not use pressurized starting fluids because vapors are flammable.

 WARNING

<p>Rapid retraction of starter cord (kickback) will pull hand and arm toward engine faster than you can let go.</p> <p>Broken bones, fractures, bruises or sprains could result.</p>
<ul style="list-style-type: none"> • When starting engine, pull cord slowly until resistance is felt, then pull rapidly. • Remove all external equipment/engine loads before starting engine. • Direct coupled equipment components such as, but not limited to, blades, impellers, pulleys, sprockets, etc., must be securely attached.

Oil Recommendations (see fig. 2)

Engine shipped from Briggs & Stratton **without oil**. Before starting engine, fill with oil. Do not over-fill.

Use a high quality detergent oil classified "For Service SF, SG, SH, SJ" or higher such as Briggs & Stratton 30W, Part Number 100005. Use no special additives with recommended oils. Do not mix oil with gasoline. Choose the SAE viscosity grade of oil from this chart that matches the starting temperature anticipated before the next oil change.



Note: Synthetic oil meeting ILSAC GF-2, API certification mark and API service symbol (shown at left) with "SJ/CF ENERGY CONSERVING" or higher, is an acceptable oil at all temperatures. **Use of synthetic oil does not alter required oil change intervals.**

* Air cooled engines run hotter than automotive engines. The use of non-synthetic multi-viscosity oils (5W-30, 10W-30, etc.) in temperatures above 40° F (4° C) will result in higher than normal oil consumption. When using a multi-viscosity oil, check oil level more frequently.

** SAE 30 oil, if used below 40° F (4° C), will result in hard starting and possible engine bore damage due to inadequate lubrication.

Check oil level. (Oil capacity is about 20 oz. or 0.6 liter.) Place engine level and clean around oil fill ①.

Remove dipstick, wipe with clean cloth ②, insert and tighten down again. Remove dipstick and check oil level. Oil should be at FULL mark ③.

If oil is required, add slowly. Tighten dipstick firmly before starting engine.

Do not overfill. Overfilling with oil may cause:

1. Smoking,
2. Hard starting,
3. Spark plug fouling,
4. Oil saturation of air filter

Fuel Recommendations

Use clean, fresh, **lead-free**, regular gasoline with a minimum of 77 octane. Leaded gasoline may be used if it is commercially available and if unleaded is unavailable. Purchase fuel in quantity that can be used within 30 days. See **Storage**.

In U.S.A. leaded gasoline may not be used. Some fuels, called oxygenated or reformulated gasolines, are gasolines blended with alcohols or ethers. Excessive amounts of these blends can damage the fuel system or cause performance problems. If any undesirable operating symptoms occur, use gasoline with a lower percentage of alcohol or ether.

This engine is certified to operate on gasoline. Exhaust Emission Control System: EM (Engine Modifications). Do not use gasoline which contains Methanol. Do not mix oil with gasoline.

For engine protection, we recommend using Briggs & Stratton Fuel Stabilizer available from an Authorized Briggs & Stratton Service Dealer.

Check fuel level.



Before refueling, allow engine to cool 2 minutes.

Clean around fuel fill before removing cap to refuel. Fill tank to approximately 1 inch below lowest portion of neck to allow for fuel expansion. Be careful not to overfill.

Starting (see fig. 3)



ALWAYS KEEP HANDS AND FEET CLEAR OF EQUIPMENT MOVING PARTS.



Do not use a pressurized starting fluid. Vapors are flammable.

Start, store and fuel equipment in level position.

Check oil level.

Start engine first time

1. Move throttle control to FAST position.
2. Push primer bulb ① firmly 5 times.



Close safety brake control handle ②, if equipped. Grasp rope handle and pull slowly until resistance is felt. Then pull cord rapidly to overcome compression, prevent kickback and start engine. Repeat if necessary. When engine starts, operate in FAST position.

3. If engine does not start after 3 pulls, push primer bulb 3 times and pull starter again.

Start engine thereafter

1. Move throttle control to FAST position.
2. Push primer bulb ① firmly 3 times.



Close safety brake control handle ②, if equipped. Grasp rope handle and pull slowly until resistance is felt. Then pull cord rapidly to overcome compression, prevent kickback and start engine. Repeat if necessary. When engine starts, operate in FAST position.

Note: If engine stopped because it ran out of fuel, refuel engine and push primer bulb 3 times. Priming is usually unnecessary when restarting a warm engine. However, cool weather may require priming to be repeated.

Stopping (see fig. 4)

Release safety brake control handle OR move throttle control to STOP.

Adjustments (see fig. 5)



To prevent accidental starting, remove spark plug wire ① and ground it before adjusting.

Throttle control adjustments

Manual controls require no adjustment.

Remote throttle control

(Air cleaner not illustrated for clarity). Loosen casing clamp screw ②. Move governor control lever ③ full travel in direction of arrow. Move equipment throttle control to FAST position. Tighten casing clamp screw.

Fixed control

This governor control lever ④ was set to the equipment manufacturer's requirements and cannot be adjusted.

Check stop switch

Move throttle control to STOP position, if so equipped. Governor control lever ⑤ must make good contact with stop switch ⑥.

Check operation of controls. Readjust if necessary.

Carburetor adjustments



The manufacturer of the equipment on which this engine is installed specifies top speed at which the engine will be operated. DO NOT EXCEED this speed.

This engine is equipped with a pulsa prime carburetor which cannot be adjusted. Your engine will idle down only about 300 to 600 rpm below top speed, which accounts for the higher than expected idle speed.

Maintenance (see figs. 6 7 8 9)

Also, see **Maintenance Schedule**, next page. Follow the hourly or calendar intervals, whichever occur first. More frequent service is required when operating in adverse conditions.



To prevent accidental starting, remove spark plug wire ❶ and ground it before servicing.

CAUTION: If engine must be tipped to transport equipment or to inspect or remove grass, **keep spark plug side of engine up.** ❷

Transporting or tipping engine spark plug down may cause:

1. Smoking,
2. Hard starting,
3. Spark plug fouling,
4. Oil saturation of air filter.

Oil service (see fig. 6)

Check oil level regularly.

Be sure correct oil level is maintained. Check every 5 hours or daily, before starting engine. See oil filling procedure, **Oil Recommendations**.

Change oil.

Change oil after first 5 hours of operation. Change oil while engine is warm. Refill with new oil of recommended SAE viscosity grade. (see fig. 2)



Before tipping engine or equipment to drain oil, drain fuel from tank by running engine until fuel tank is empty.

If draining oil from top of engine, keep spark plug ❷ side up.

By removing drain plug ❸ with a ratchet and square extension ❹, oil can be drained from engine bottom.

Air cleaner service (see fig. 7)

Replace Oil-Foam® element if very dirty or damaged.

- Remove screw.
- Carefully remove air cleaner to prevent debris from falling into carburetor.
- Take air cleaner apart and clean all parts. Wash Oil-Foam® element ❶ in liquid detergent and water. Squeeze dry in a clean cloth. **Saturate** Oil-Foam® element in engine oil and squeeze in a clean cloth to remove excess oil.
- Install Oil-Foam® element and cup, if equipped, in body.

Note: On Style 2 air cleaner ❷, install element so lip extends over edge of body to form protective seal when cover is assembled.

- Install air cleaner securely on carburetor with screw.

Maintenance Cont'd

Spark plug service (see fig. 8)



DO NOT check for spark with spark plug removed. Use only Briggs & Stratton Spark Tester ❶, to check for spark.

DO NOT crank engine with spark plug removed. If engine is flooded, place throttle in FAST and crank until engine starts.

Spark plug gap ❷ should be .76 mm or 0.030 in.

Replace spark plug every 100 hours or every season, whichever occurs first. Spark plug wrench is available from any Authorized Briggs & Stratton Service Dealer.

Note: In some areas, local law requires using a resistor spark plug to suppress ignition signals. If this engine was originally equipped with resistor spark plug, use same type of spark plug for replacement.

Keep engine clean (see fig. 9)

Periodically remove grass and chaff build-up from engine. Clean finger guard ❶. Do not spray engine with water to clean because water could contaminate fuel. Clean with a brush or compressed air.



Accumulation of debris around muffler ❷ could cause a fire. Inspect and clean before every use.

If muffler is equipped with spark arrester screen ❸, remove spark arrester screen for cleaning and inspection. Replace if damaged.

Clean cooling system. Grass or chaff may clog engine's air cooling system, especially after prolonged service cutting tall, dry grass. Internal cooling fins and surfaces may require cleaning to prevent overheating and engine damage.

Remove 3 screws ❹ and lift blower housing to clean areas within heavy line ❺.

Do not loosen 2 band brake bracket screws ❻.

Do not bend or remove flywheel guard ❼.

Maintenance Schedule

Follow the hourly or calendar intervals, whichever occur first. More frequent service is required when operating in adverse conditions noted below.

First 5 Hours

- Change oil

Every 5 hours or daily

- Check oil level
- Clean finger guard
- Clean around muffler

Every 25 hours or every season

- Change oil if operating under heavy load or high ambient temperature
- Service air cleaner Oil-Foam® element*

Every 50 hours or every season

- Change oil
- Inspect spark arrester, if equipped.

Every 100 hours or every season

- Clean cooling system*
- Replace spark plug

* *Clean more often under dusty conditions, or when airborne debris is present or after prolonged operation cutting tall, dry grass.*

Partial List of Genuine Briggs & Stratton Parts

Briggs & Stratton (or equivalent)	
Part	Part No.
Oil (20 oz.)	100005
Oil pump kit (uses standard electric drill to remove oil from engine quickly)	5056
Fuel stabilizer (1 oz., 30 ml single use pouch)	992030
Fuel stabilizer (4.2 oz., 125 ml bottle)	999005E (5041)
Oil-Foam® air cleaner element	698369
Oil-Foam®	272235 (5047)
air cleaner element used with cup	
Resistor spark plug	802592E
Standard spark plug	492167E
Long life platinum spark plug (used on most L-head engines)	992041 (5062)
Spark tester	19368
Spark plug wrench	89838 (5023)
Spark arrester	398067

Storage

Engines stored over 30 days need to be protected or drained of fuel to prevent gum from forming in fuel system or on essential carburetor parts.

For engine protection, we recommend use of Briggs & Stratton Fuel Stabilizer available from an Authorized Briggs & Stratton Service Dealer. Mix stabilizer with fuel in fuel tank or storage container. Run engine for a short time to circulate stabilizer through carburetor. Engine and fuel can be stored up to 24 months.

Note: If stabilizer is not used or if engine is operating on gasoline containing alcohol, e.g. gasohol, remove all fuel from tank and run engine until it stops from lack of fuel.

1. Change oil. See **Oil service.** (see figs. 2 6)
2. Remove spark plug and pour about 15 ml (1/2 oz) of engine oil into cylinder. Replace spark plug and crank slowly to distribute oil.
3. Clean grass and chaff from cylinder and cylinder head fins, under finger guard and under, around and behind muffler/converter.
4. Store in a clean and dry area, but NOT near a stove, furnace or water heater which uses a pilot light or any device that can create a spark.

Service

See an Authorized Briggs & Stratton Service Dealer. Each one carries a stock of Genuine Briggs & Stratton Parts and is equipped with special service tools. Trained mechanics assure expert repair service on all Briggs & Stratton engines. Only dealers advertising as "Authorized Briggs & Stratton" are required to meet Briggs & Stratton standards.

When you purchase equipment powered by a Briggs & Stratton engine, you are assured of highly skilled, reliable service at more than 30,000 Authorized Service Dealers worldwide, including more than 5,000 Master Service Technicians. Look for these signs wherever Briggs & Stratton service is offered.



You may locate your nearest Authorized Briggs & Stratton Service Dealer in our dealer locator map on our web site www.briggsandstratton.com or in the "Yellow Pages" directory under "Engines, Gasoline" or "Gasoline Engines," or "Lawn Mowers" or similar category.



Note: Walking fingers logo and "Yellow Pages" are registered trademarks in various jurisdictions.

An illustrated shop manual includes "Theories of Operation," common specifications and detailed information covering adjustment, tune-up and repair of Briggs & Stratton L-head, single cylinder, 4 cycle engines. Order P/N 270962 from an Authorized Briggs & Stratton Service Dealer.

Insist on Genuine Briggs & Stratton replacement parts with our logo on the box and/or part. Non-original parts may not perform as well and may void your warranty.

BRIGGS & STRATTON ENGINE OWNER WARRANTY POLICY

Effective July 1, 2004 replaces all undated Warranties and all Warranties dated before July 1, 2004

LIMITED WARRANTY

Briggs & Stratton Corporation will repair or replace, free of charge, any part(s) of the engine that is defective in material or workmanship or both. Transportation charges on parts submitted for repair or replacement under this warranty must be borne by purchaser. This warranty is effective for the time periods and subject to the conditions stated below. For warranty service, find the nearest Authorized Service Dealer in our dealer locator map at www.briggsandstratton.com, or by calling 1-800-233-3723, or as listed in the "Yellow Pages".

THERE IS NO OTHER EXPRESS WARRANTY. IMPLIED WARRANTIES, INCLUDING THOSE OF MERCHANTABILITY AND FITNESS FOR A PARTICULAR PURPOSE, ARE LIMITED TO ONE YEAR FROM PURCHASE, OR TO THE EXTENT PERMITTED BY LAW ANY AND ALL IMPLIED WARRANTIES ARE EXCLUDED. LIABILITY FOR INCIDENTAL OR CONSEQUENTIAL DAMAGES ARE EXCLUDED TO THE EXTENT EXCLUSION IS PERMITTED BY LAW. Some states or countries do not allow limitations on how long an implied warranty lasts, and some states or countries do not allow the exclusion or limitation of incidental or consequential damages, so the above limitation and exclusion may not apply to you. This warranty gives you specific legal rights and you may also have other rights which vary from state to state and country to country.

OUR PRODUCT

Vanguard™	ELS™ I/C® Industrial Plus™ Intek™ (Sleeve Bore)	Force™ Intek™ (Kool Bore) Power Built™ OHV Quantum® Quattro™ Q45™ Sprint™	Classic™	Etek™
-----------	---	--	----------	-------

WARRANTY PERIOD*

	Vanguard™	ELS™ I/C® Industrial Plus™ Intek™ (Sleeve Bore)	Force™ Intek™ (Kool Bore) Power Built™ OHV Quantum® Quattro™ Q45™ Sprint™	Classic™	Etek™
Consumer Use	2 years	2 years	2 years	1 year	1 year
Commercial Use		1 year	90 days	90 days	

* Note the following special warranty periods: 2 years for Classic™ engines in the European Union and Eastern European countries, for all consumer products in the European Union, and for emission control systems on engines certified by EPA and CARB. 5 years for consumer use, 90 days for commercial use of Touch-N-Mow® starter on Quantum® and Intek™ engines. Engines used in competitive racing or on commercial or rental tracks are not warrantied.

The warranty period begins on the date of purchase by the first retail consumer or commercial end user, and continues for the period of time stated in the table above. "Consumer use" means personal residential household use by a retail consumer. "Commercial use" means all other uses, including use for commercial, income producing or rental purposes. Once an engine has experienced commercial use, it shall thereafter be considered as a commercial use engine for purposes of this warranty.

NO WARRANTY REGISTRATION IS NECESSARY TO OBTAIN WARRANTY ON BRIGGS & STRATTON PRODUCTS. SAVE YOUR PROOF OF PURCHASE RECEIPT. IF YOU DO NOT PROVIDE PROOF OF THE INITIAL PURCHASE DATE AT THE TIME WARRANTY SERVICE IS REQUESTED, THE MANUFACTURING DATE OF THE PRODUCT WILL BE USED TO DETERMINE THE WARRANTY PERIOD.

ABOUT YOUR ENGINE WARRANTY

Briggs & Stratton welcomes warranty repair and apologizes to you for being inconvenienced. Any Authorized Service Dealer may perform warranty repairs. Most warranty repairs are handled routinely, but sometimes requests for warranty service may not be appropriate. For example, warranty would not apply if engine damage occurred because of misuse, lack of routine maintenance, shipping, handling, warehousing or improper installation. Similarly, warranty is void if the serial number of the engine has been removed or the engine has been altered or modified.

If a customer differs with the decision of the Service Dealer, an investigation will be made to determine whether the warranty applies. Ask the Service Dealer to submit all supporting facts to his Distributor or the Factory for review. If the Distributor or the Factory decides that the claim is justified, the customer will be fully reimbursed for those items that are defective. To avoid misunderstanding which might occur between the customer and the Dealer, listed below are some of the causes of engine failure that the warranty does not cover.

Normal wear:

Engines, like all mechanical devices, need periodic parts service and replacement to perform well. Warranty will not cover repair when normal use has exhausted the life of a part or an engine.

Improper maintenance:

The life of an engine depends upon the conditions under which it operates, and the care it receives. Some applications, such as tillers, pumps and rotary mowers, are very often used in dusty or dirty conditions, which can cause what appears to be premature wear. Such wear, when caused by dirt, dust, spark plug cleaning

grit, or other abrasive material that has entered the engine because of improper maintenance, is not covered by warranty.

This warranty covers engine related defective material and/or workmanship only, and not replacement or refund of the equipment to which the engine may be mounted. Nor does the warranty extend to repairs required because of:

1. PROBLEMS CAUSED BY PARTS THAT ARE NOT ORIGINAL BRIGGS & STRATTON PARTS.
2. Equipment controls or installations that prevent starting, cause unsatisfactory engine performance, or shorten engine life. (Contact equipment manufacturer.)
3. Leaking carburetors, clogged fuel pipes, sticking valves, or other damage, caused by using contaminated or stale fuel. (Use clean, fresh, lead-free gasoline and Briggs & Stratton Fuel Stabilizer, Part No. 5041.)
4. Parts which are scored or broken because an engine was operated with insufficient or contaminated lubricating oil, or an incorrect grade of lubricating oil (check oil level daily or after every 8 hours of operation. Refill when necessary and change at recommended intervals.) OIL GARD® may not shut down running engine. Engine damage may occur if oil level is not properly maintained. Read Operating & Maintenance Instructions.
5. Repair or adjustment of associated parts or assemblies such as clutches, transmissions, remote controls, etc., which are not manufactured by Briggs & Stratton.
6. Damage or wear to parts caused by dirt, which entered the engine because of improper air cleaner maintenance, re-assembly, or use of a non-original air cleaner element or cartridge. (At recommended intervals, clean and re-oil

the Oil-Foam® element or the foam pre-cleaner, and replace the cartridge.) Read Operating & Maintenance Instructions.

7. Parts damaged by over-speeding, or overheating caused by grass, debris, or dirt, which plugs or clogs the cooling fins, or flywheel area, or damage caused by operating the engine in a confined area without sufficient ventilation. (Clean fins on the cylinder, cylinder head and flywheel at recommended intervals.) Read Operating & Maintenance Instructions.
8. Engine or equipment parts broken by excessive vibration caused by a loose engine mounting, loose cutter blades, unbalanced blades or loose or unbalanced impellers, improper attachment of equipment to engine crankshaft, over-speeding or other abuse in operation.
9. A bent or broken crankshaft, caused by striking a solid object with the cutter blade of a rotary lawn mower, or excessive v-belt tightness.
10. Routine tune-up or adjustment of the engine.
11. Engine or engine component failure, i.e., combustion chamber, valves, valve seats, valve guides, or burned starter motor windings, caused by the use of alternate fuels such as, liquified petroleum, natural gas, altered gasolines, etc.

Warranty is available only through service dealers which have been authorized by Briggs & Stratton Corporation. Your nearest Authorized Service Dealer is listed in the "Yellow Pages"™ of your telephone directory under "Engines, Gasoline" or "Gasoline Engines," "Lawn Mowers," or similar category.

Briggs & Stratton Engines Are Made Under One Or More Of The Following Patents: Design D-247,177 (Other Patents Pending)										
6,691,683	6,520,141	6,325,036	6,145,487	6,012,420	5,803,035	5,548,955	5,243,878	5,138,996	4,875,448	D 476,629
6,647,942	6,495,267	6,311,663	6,142,257	5,992,367	5,765,713	5,546,901	5,235,943	5,086,890	4,819,593	D 457,891
6,622,683	6,494,175	6,284,123	6,135,426	5,904,124	5,732,555	5,445,014	5,234,038	5,070,829	4,720,638	D 368,187
6,615,787	6,472,790	6,263,852	6,116,212	5,894,715	5,645,025	5,503,125	5,228,487	5,058,544	4,719,682	D 375,963
6,617,725	6,460,502	6,260,529	6,105,548	5,887,678	5,642,701	5,501,203	5,197,426	5,040,644	4,633,556	D 309,457
6,603,227	6,456,515	6,242,828	6,347,614	5,852,951	5,628,352	5,497,679	5,197,425	5,009,208	4,630,498	D 372,871
6,595,897	6,382,166	6,239,709	6,082,323	5,843,345	5,619,845	5,320,795	5,197,422	4,996,956	4,522,080	D 361,771
6,595,176	6,369,532	6,237,555	6,077,063	5,823,153	5,606,948	5,301,643	5,191,864	4,977,879	4,520,288	D 356,951
6,584,964	6,356,003	6,230,678	6,064,027	5,819,513	5,606,851	5,271,363	5,188,069	4,977,877	4,512,499	D 309,457
6,557,833	6,349,688	6,213,083	6,040,767	5,813,384	5,605,130	5,269,713	5,186,142	4,971,219	4,453,507	D 308,872
6,542,074	6,347,614	6,202,616	6,014,808	5,809,958	5,497,679	5,265,700	5,150,674	4,895,119	4,430,984	D 308,871

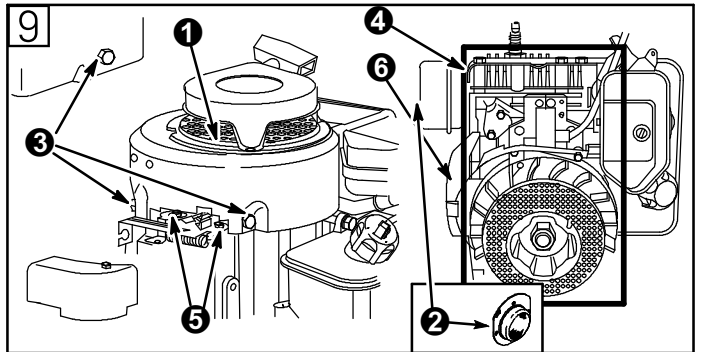
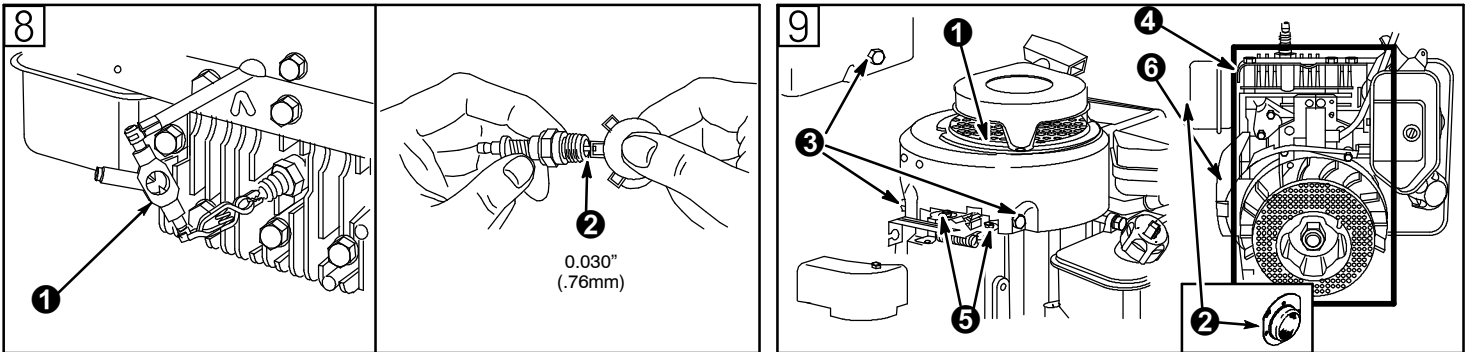
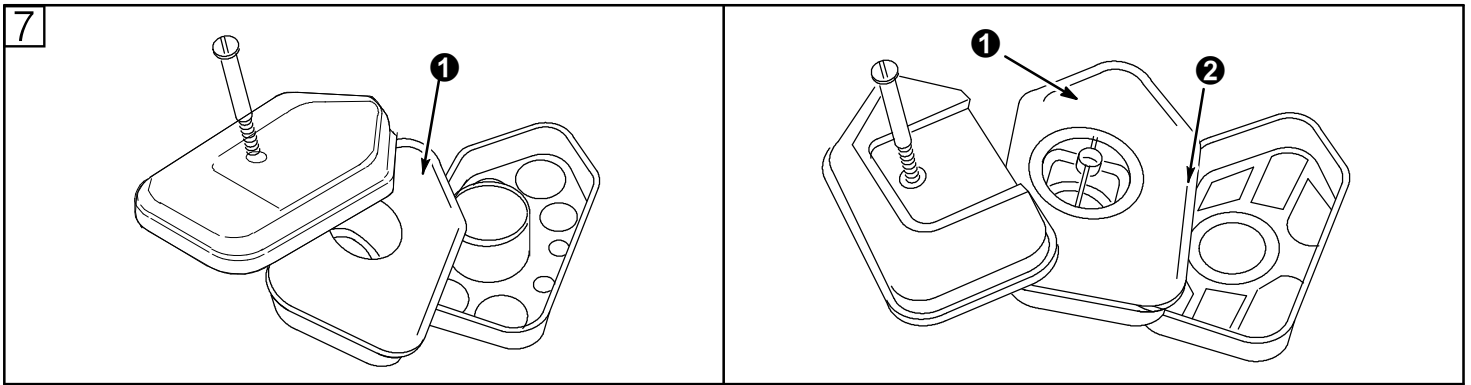
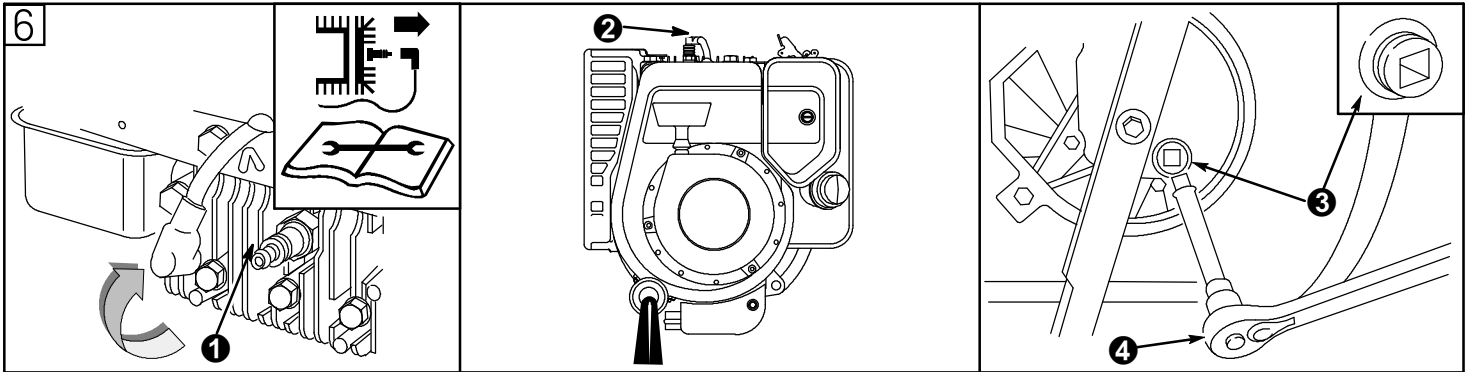
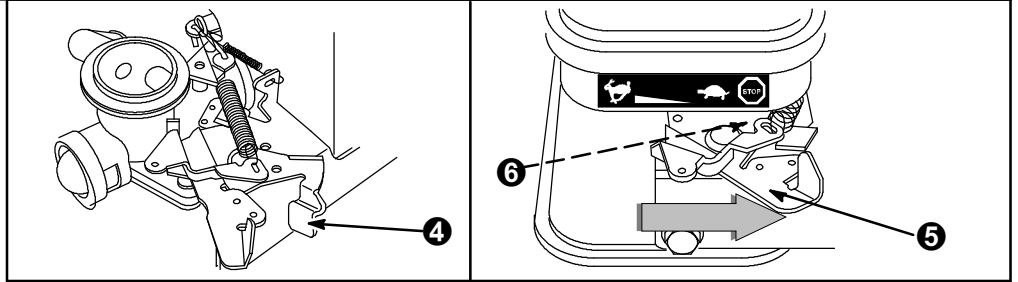
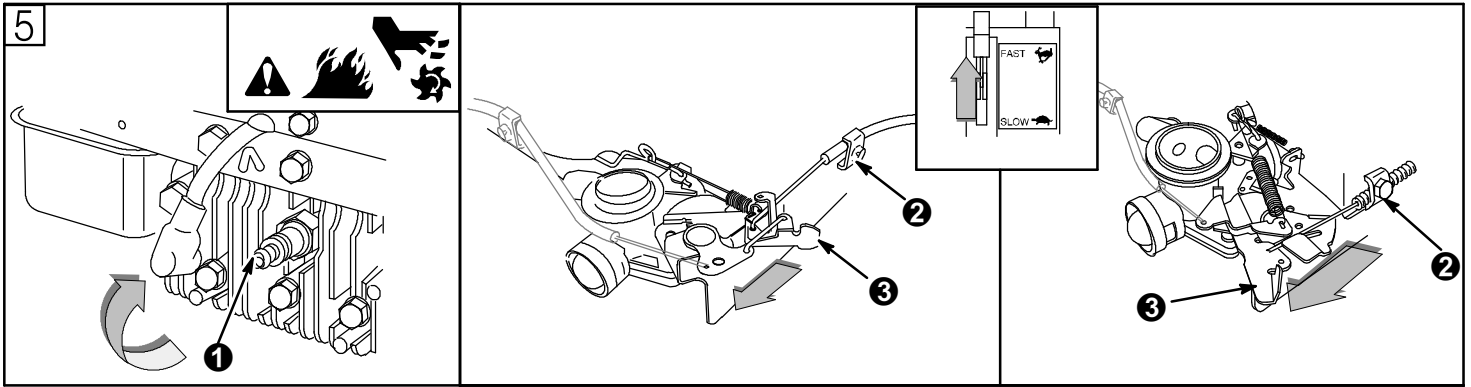

**Briggs & Stratton Corporation (B&S) and the United States Environmental Protection Agency (U.S. EPA)
Emission Control System Warranty Statement (Owner's Defect Warranty Rights and Obligations)**

EMISSION CONTROL WARRANTY COVERAGE IS APPLICABLE TO CERTIFIED MODEL YEAR 1997 AND LATER ENGINES WHICH ARE PURCHASED AND USED IN THE UNITED STATES (EXCLUDING CALIFORNIA (AND AFTER JANUARY 1, 2001 IN CANADA)).

United States and Canada Emission Control Defects Warranty Statement

The United States Environmental Protection Agency (US EPA) and B&S are pleased to explain the Emission Control System Warranty on your model year 2000 and later small non-road engine. New non-road, spark-ignition engines certified for model year 1997 and later must meet stringent standards set forth by the USEPA. B&S must warrant the emission control system on your small non-road engine for the periods of time listed below, provided there has been no abuse, neglect or improper maintenance of your small non-road engine.

Your emission control system includes parts such as the carburetor, air cleaner, ignition system, muffler and catalytic converter. Also included may be connectors and other emission related assemblies.

Where a warrantable condition exists, B&S will repair your small non-road engine at no cost to you including diagnosis, parts and labor.

Briggs & Stratton Emission Control Defects Warranty Coverage

Small non-road engines are warranted relative to emission control parts defects for a period of two years, subject to provisions set forth below. If any covered part on your small non-road engine is defective, the part will be repaired or replaced by B&S.

Owner's Warranty Responsibilities

As the small non-road engine owner, you are responsible for the performance of the required maintenance listed in your Operating and Maintenance Instructions. B&S recommends that you retain all your receipts covering maintenance on your small non-road engine, but B&S cannot deny warranty solely for the lack of receipts or for your failure to ensure the performance of all scheduled maintenance.

As the small non-road engine owner, you should however be aware that B&S may deny you warranty coverage if your small non-road engine or a part has failed due to abuse, neglect, improper maintenance or unapproved modifications.

You are responsible for presenting your small non-road engine to an Authorized B&S Service Dealer as soon as a problem exists. The undisputed warranty repairs should be completed in a reasonable amount of time, not to exceed 30 days.

If you have any questions regarding your warranty rights and responsibilities, you should contact a B&S Service Representative at 1-414-259-5262.

The emission warranty is a defects warranty. Defects are judged on normal engine performance. The warranty is not related to an in-use emission test.

Briggs & Stratton Emission Control Defects Warranty Provisions

The following are specific provisions relative to your Emission Control Defects Warranty Coverage. It is in addition to the B&S engine warranty for non-regulated engines found in the Operator/Owner Manual.

1. Warranted Parts

Coverage under this warranty extends only to the parts listed below (the emission control systems parts) to the extent these parts were present on the engine purchased.

a. Fuel Metering System

- Cold start enrichment system (soft choke)
- Carburetor and internal parts
- Fuel Pump

b. Air Induction System

- Air cleaner
- Intake manifold

c. Ignition System

- Spark plug(s)
- Magneto ignition system

d. Catalyst System

- Catalytic converter
- Exhaust manifold
- Air injection system or pulse valve

e. Miscellaneous Items Used in Above Systems

- Vacuum, temperature, position, time sensitive valves and switches
- Connectors and assemblies

2. Length of Coverage

B&S warrants to the initial owner and each subsequent purchaser that the Warranted Parts shall be free from defects in materials and workmanship which caused the failure of the Warranted Parts for a period of two years from the date the engine is delivered to a retail purchaser.

3. No Charge

Repair or replacement of any Warranted Part will be performed at no charge to the owner, including diagnostic labor which leads to the determination that a Warranted Part is defective, if the diagnostic work is performed at an Authorized B&S Service Dealer. For emissions warranty service contact your nearest Authorized B&S Service Dealer as listed in the "Yellow Pages" under "Engines, Gasoline," "Gasoline Engines," "Lawn Mowers," or similar category.

4. Claims and Coverage Exclusions

Warranty claims shall be filed in accordance with the provisions of the B&S Engine Warranty Policy. Warranty coverage shall be excluded for failures of Warranted Parts which are not original B&S parts or because of abuse, neglect or improper maintenance as set forth in the B&S Engine Warranty Policy. B&S is not liable to cover failures of Warranted Parts caused by the use of add-on, non-original, or modified parts.

5. Maintenance

Any Warranted Part which is not scheduled for replacement as required maintenance or which is scheduled only for regular inspection to the effect of "repair or replace as necessary" shall be warranted as to defects for the warranty period. Any Warranted Part which is scheduled for replacement as required maintenance shall be warranted as to defects only for the period of time up to the first scheduled replacement for that part. Any replacement part that is equivalent in performance and durability may be used in the performance of any maintenance or repairs. The owner is responsible for the performance of all required maintenance, as defined in the B&S Operating and Maintenance Instructions.

6. Consequential Coverage

Coverage hereunder shall extend to the failure of any engine components caused by the failure of any Warranted Part still under warranty.

**IMPORTANT ENGINE INFORMATION
BRIGGS & STRATTON CORPORATION
FAMILY YBSXS.1481HH 274459**

**THIS ENGINE CONFORMS TO 2000-2001
CALIFORNIA EMISSION REGULATIONS FOR
SMALL OFFROAD ENGINES AND EPA
PHASE 1 REGULATIONS FOR SMALL
NON-ROAD ENGINES. REFER TO OWNER'S
MANUAL FOR MAINTENANCE
SPECIFICATIONS, AND ADJUSTMENTS.**

**This is a generic representation
of the emission label typically
found on a certified engine.**

**La Corporation Briggs & Stratton (B&S),
et le Bureau de protection environnementale des Etats-Unis (US EPA)**

Garantie sur le système d'échappement (Garantie contre les défauts, droits et obligations du propriétaire)

LA GARANTIE SUR LE SYSTÈME D'ÉCHAPPEMENT EST APPLICABLE SUR LES MOTEURS CERTIFIÉS CERTIFIÉS DE 1997 ET LES ANNÉES SUIVANTES QUI ONT ÉTÉ ACHETÉS ET UTILISÉS AUX ÉTATS-UNIS (SANS COMPTE CALIFORNIE) ET AU CANADA.

Déclaration de garantie sur le système d'échappement pour les Etats-Unis et le Canada

Le Bureau américain de protection environnementale (U.S. EPA) et B&S sont heureux d'expliquer la garantie sur le système d'échappement des petits moteurs hors-route de votre modèle 2000 et des années ultérieures (SORE). Les nouveaux moteurs hors route à bougie d'allumage certifiés pour les modèles de 1997 et plus, doivent rencontrer des normes similaires mises de l'avant par le U.S. EPA. Briggs & Stratton garantit le système de contrôle d'échappement de votre moteur pour la période de temps mentionnée ci-contre, sauf s'il a fait l'objet d'abus, de négligence ou d'un entre-

Les petits moteurs hors route sont garantis contre la défectuosité des pièces du système de contrôle d'échappement pour une période de 2 ans, sujette aux conditions stipulées ci-contre. Si n'impor-

En tant que propriétaire d'un petit moteur hors route, vous êtes responsable de veiller à l'exécution de l'entretien requis tel que stipulé dans votre manuel d'opération et d'entretien. B&S vous recommande de conserver tous les reçus couvrant les travaux d'entretien de votre petit moteur hors route, mais B&S ne peut refuser la garantie en raison d'absence de reçus ou pour défaut d'avoir suivi tout l'échéancier du programme d'entretien.

En tant que propriétaire d'un petit moteur hors route, vous devez être informé que B&S peut refuser d'honorer cette garantie si la défectuosité de votre moteur ou d'une partie de votre moteur est due à un emploi abusif, une négligence, un entretien incorrect ou une modification non approuvée.

Dispositions de la garantie du système d'échappement Briggs & Stratton

Ce qui suit concerne les dispositions spécifiques relativement à votre garantie sur le système de contrôle d'échappement. C'est une addition à la garantie B&S pour les moteurs non réglementés contenue dans le manuel d'entretien et d'utilisation.

1. Pièces sous garantie

La couverture de cette garantie ne s'applique que sur les pièces listées ci-contre (les parties du système de contrôle d'échappement) dans la mesure où ces pièces étaient présentes sur le moteur au moment de l'achat.

- a. Système de dosage du carburant
 - Système d'enrichissement de démarrage à froid
 - Carburateur et parties internes
 - Pompe à essence
- b. Système d'induction d'air
 - Filtre à air
 - Tubulure d'admission
- c. Système d'ignition
 - Bougies d'allumage
 - Système d'allumage électromagnétique
- d. Système catalyseur
 - Convertisseur catalytique
 - Collecteur d'échappement
 - Système d'injection d'air ou à pulsion
- e. Autres pièces utilisées dans les systèmes ci-haut mentionnés
 - Soupapes et interrupteurs de dépression, de température, de position.
 - Connecteurs et assemblages.

2. Durée de la couverture

B&S garantit le propriétaire initial et tous les acheteurs subséquents que les pièces sous garantie sont exemptes de vice de matière ou de fabrication qui pourraient causer des défauts des pièces sous garantie pour une période de deux ans à partir de la date à laquelle le moteur a été livré à l'acheteur.

rien inapproprié. Votre système de contrôle d'échappement comprend des pièces telles que le carburateur, le filtre à air, le système d'ignition, le silencieux et le convertisseur catalytique. Il peut aussi comprendre les connecteurs et autres pièces reliées à l'émission. Lorsqu'il y a condition à garantie, B&S réparera gratuitement votre petit moteur hors-route incluant le diagnostic, les pièces et la main d'œuvre.

Si vous avez des questions relativement à votre garantie, vos droits et responsabilités, veuillez communiquer avec un représentant de service B&S au numéro 1-414-259-5262. La garantie du système d'échappement est une garantie contre les défauts. Les défauts sont jugés en fonction d'une utilisation normale du moteur. La garantie n'est pas reliée à un test d'échappement effectué à l'intérieur.

Vous avez la responsabilité d'apporter votre petit moteur hors route à un détaillant autorisé B&S aussitôt que survient un problème. Les réparations sous garantie doivent être complétées dans un délai raisonnable ne devant pas excéder 30 jours.

Si vous avez des questions relativement à votre garantie, vos droits et responsabilités, veuillez communiquer avec un représentant de service B&S au numéro 1-414-259-5262.

La garantie du système d'échappement est une garantie contre les défauts. Les défauts sont jugés en fonction d'une utilisation normale du moteur. La garantie n'est pas reliée à un test d'échappement effectué à l'intérieur.

3. Aucuns Frais

La réparation ou le remplacement de toute pièce sous garantie sera effectuée sans aucuns frais pour le propriétaire, incluant les frais de main d'œuvre pour le diagnostic afin de déterminer si la pièce sous garantie est défectueuse, conditionnel à ce que le diagnostic soit effectué chez un détaillant autorisé B&S. Pour la garantie relative au système d'échappement, communiquez avec le détaillant autorisé B&S le plus proche tel que listé dans les pages jaunes de votre localité sous la rubrique moteur à essence, tondeuse ou autre catégorie similaire.

4. Réclamations et exclusions de la couverture.

Les réclamations de garantie doivent être complétées en accord avec les dispositions de la politique de garantie B&S. La garantie ne couvre pas les défauts de pièces qui ne sont pas des pièces d'origine B&S ou dans le cas d'abus, négligence ou d'un entretien inapproprié. La garantie B&S ne couvre pas les défauts de pièces sous garantie qui ont fait l'objet d'ajouts, ont été modifiées ou de pièces qui ne sont pas des pièces B&S d'origine.

5. Entretien

Toute pièce sous garantie qui n'est pas remplacée au moment requis selon le manuel d'entretien ou qui est planifiée seulement pour une inspection régulière sous la mention « réparer ou remplacer si nécessaire » est garantie contre toute défectuosité pour la période de garantie. Toute pièce sous garantie qui est planifiée pour un remplacement tel que requis dans l'entretien est garantie contre toute défectuosité seulement pour la période de temps qui va jusqu'au premier remplacement prévu pour cette pièce. Toute pièce de remplacement équivalente en performance et durabilité peut être utilisée pour l'entretien ou la réparation. Le propriétaire est responsable de l'exécution de tout entretien requis tel que défini dans le manuel d'instruction B&S sur l'entretien et la réparation.

6. Couverture indirecte

La couverture ci-contre s'étend à toute défectuosité des composantes du moteur causée par la défectuosité de n'importe quelle pièce couverte par la garantie et dont la garantie est encore en vigueur.

Ceci est une représentation des étiquettes d'émission que vous retrouverez sur les moteurs certifiés :

