

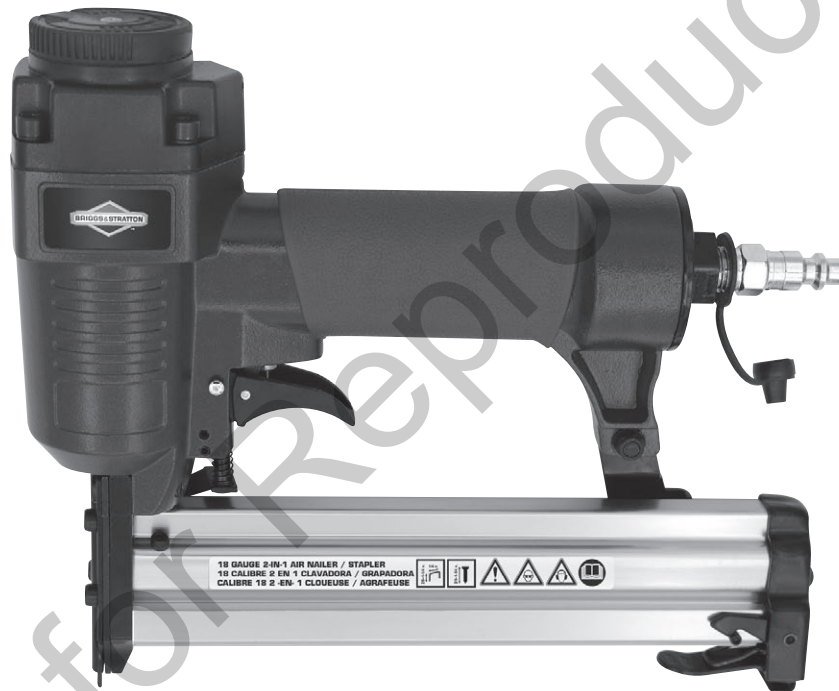

18 GAUGE 2-IN-1 AIR NAILER / STAPLER Operator's Manual



Product Model # 6390-00
Manual # 80018898



Read and understand this instruction manual thoroughly before using the product. It contains important information for your safety as well as operating and maintenance advice.

BRIGGS & STRATTON CORPORATION
MILWAUKEE, WISCONSIN, U.S.A.

BRIGGS & STRATTON IS A TRADEMARK OF BRIGGS & STRATTON CORPORATION AND IS USED UNDER LICENSE TO ALTON INDUSTRY LTD. GROUP

Thank you for purchasing this quality-built **Briggs & Stratton™** air tool. We are pleased that you've placed your confidence in the **Briggs & Stratton** brand. When operated and maintained according to the instructions in this manual, your Briggs & Stratton air tool will provide reliable service.

Where to Find Us

You can contact Briggs & Stratton Customer Service by phone at **(800) 743-4115**, or on the Internet at **BRIGGSandSTRATTON.COM**.

Date Purchased

--	--	--	--	--	--

▲ WARNING Some dust created by using power tools contains chemicals known to the state of California to cause cancer and birth defects or other reproductive harm. This product contains one or more chemicals known to the State of California to cause cancer and birth defects or other reproductive harm. Wash hands after handling.

BRIGGS & STRATTON IS A TRADEMARK OF BRIGGS & STRATTON CORPORATION AND IS USED UNDER LICENSE TO ALTON INDUSTRY LTD. GROUP

BRIGGS&STRATTON
MILWAUKEE, WI 53201
800 743 4115

Copyright ©2016. All rights reserved.
Made in China

General Safety Information

The safety alert symbol ▲ is used to identify safety information about hazards that can result in personal injury.

A signal word **DANGER**, **WARNING** or **CAUTION** is used with the alert symbol to indicate the likelihood and the potential severity of injury.

▲ **DANGER** Indicates a hazardous situation that, if not avoided, will result in death or serious injury. This signal word is to be limited to the most extreme situations.

▲ **WARNING** Indicates a hazardous situation that, if not avoided, could result in death or serious injury.

▲ **CAUTION** Indicates a hazardous situation that, if not avoided, could result in minor or moderate injury.

NOTICE Indicates information considered important, but not hazard-related.

▲ **WARNING** Read manufacturer's instructions.

▲ **WARNING**

- Improper operation or maintenance of this tool could result in personal injury. Read and understand all warnings and operation instructions before using this tool.
- When using this tool, these basic safety precautions should always be followed to reduce the risk of personal injury.

Workplace conditions

1. Keep the work area clean and well lighted. Cluttered benches and dark areas increase risks of electric shock, fire, and injury to persons. Be aware of excess air hose left in your walking way or on the working surface. Slips, trips and falls are major causes of workplace injury.
2. Ensure that there are no electric cables, gas pipes, etc., which can cause a hazard if damaged by use of the tool.
3. Do not operate the tool in explosive atmospheres, such as in the presence of flammable liquids, gases, or dust. The tool is able to create sparks resulting in the ignition of the dust or fumes.
4. Keep bystanders, children, and visitors away while operating the tool. Distractions are able to result in the loss of control of the tool.

Personal safety

1. Stay alert and use common sense. Watch what you are doing. Do not operate the tool when you are tired or under the influence of alcohol, drugs or medication. A moment of inattention while operating the tool increases the risk of injury to persons.
2. Dress properly. Do not wear loose clothing. Tie up or cover long hair, remove any jewelry, necklaces, etc., which might become caught by the tool at operation.
3. Do not overreach. Keep proper footing and balance at all times. Proper footing and balance enables better control of the tool in unexpected situations.

4. Use safety equipment. A dust mask, non-skid safety shoes and a hard hat must be used for the applicable conditions. Wear heavy-duty work gloves during use.
5. Always wear eye protection. Wear ANSI-approved safety goggles with side shields.
6. Always wear hearing protection when using the tool. Prolonged exposure to high intensity noise is able to cause hearing loss.
7. Do not attach the hose or tool to your body. Attach the hose to the structure to reduce the risk of loss of balance if the hose shifts.

Use of air tools

1. Never use oxygen, carbon dioxide, combustible gases or any other type of bottled gas as a power source of this tool. Such gases are capable of explosion and serious injury to persons.
2. Never connect to an air source that is capable of exceeding 200 psi. Over pressurizing the tool may cause bursting, abnormal operation, breakage of the tool or serious injury to persons. Always verify prior to using this tool that the air source has been adjusted to the rated air pressure range.
3. Do not connect the air supply hose to the tool with your finger on the trigger.
4. Never leave the operating tool unattended. Disconnect the air hose when the tool is not in use.
5. Keep the air supply hose away from heat, oil, and sharp edges.
6. Check air supply hose for wear and/or leaks before each use. Make sure that all connections are tight and secure.
7. Do not use the tool for any other than its intended use.
8. Do not carry out any alternations and/or modifications to the tool.
9. Always disconnect the tool from air supply before replacing any accessories, performing any repair and maintenance, moving to another work area, or passing the tool to another person.
10. Only use accessories that are identified by the manufacturer for the specific tool model. Use of an accessory not intended for use with the specific tool model increases the risk of injury to persons.
11. Never tool the tool if it is defective, damaged, or operating abnormally.
12. Check for misalignment or binding of moving parts, breakage of parts and any other condition that affects the tool operation. If damaged, have the tool serviced before using.
13. Keep working parts of the tool away from hands and body.
14. Do not carry the tool by the air hose.
15. Do not apply excessive force of any kind to the tool. Let the tool perform the work at the rate as it was designed.
16. Use clamps or another practical way to secure and support the workpiece to a stable platform. Holding the work by hand or against the body is unstable and can lead to loss of control.
17. Do not remove any labels on the tool. Replace if they become obscured or damaged.

18. Use only the lubricants supplied with the tool or specified by the manufacturer.
19. Always maintain the tool with care. Keep it clean for the best and safest performance.
20. It is not recommended that quick change couplings should be located directly at the air inlet, as they add weight and could fail due to vibration.
21. Install an in-line shutoff valve to allow immediate control over the air supply in an emergency, even if a hose is ruptured.
22. This tool vibrates with use. Continuous operation of this tool might be harmful to your hands or arms. Stop using the tool if discomfort, a tingling feeling or pain occurs. Resume work after recovery. Seek medical advice if a serious symptom occurs.
23. When serving the tool, use only identical replacement parts. Use only authorized parts.
24. Tool service must be performed only by qualified repair personnel.
25. Always store the tool in a dry and safe place out of reach of children or untrained operators.

Air nailer/stapler safety instructions

1. Avoid unintentional starting. Be sure that the trigger is released before connecting to the air supply.
2. Do not use the tool if the trigger does not turn the tool on or off. Any tool that cannot be controlled with the trigger is dangerous and must not be used until repaired.
3. Keep finger away from the trigger when not driving fasteners to avoid accidental firing.
4. Disconnect the tool from air supply before making adjustments, doing the maintenance, clearing jams, touching the safety nosepiece, leaving work area, loading, or unloading the tool. Such precautionary measures reduce the risk of injury to persons.
5. Use only those fasteners listed in the specifications of this manual. Fasteners not identified for use with this tool by the manufacturer can result in a risk of injury to persons or tool damage when used in this tool.
6. Always assume that tool contains fasteners.
7. Do not point the tool toward yourself or anyone whether it contains fasteners or not.
8. Do not actuate the tool unless the tool is placed firmly against the workpiece.
9. Do not load the tool with fasteners when any one of the operating controls, such as the trigger or safety nosepiece, is activated.
10. Do not remove, tamper with, or otherwise cause the tool operating controls to become inoperable.
11. Fire fasteners into an appropriate work surface only. Do not attempt to fire fasteners into surfaces too hard to penetrate. Do not drive fasteners on top of other fasteners, or at too steep of an angle. Fasteners can ricochet causing personal injury.
12. Do not fire fasteners too close to the edge of a workpiece. They may split the workpiece and fly free, causing personal injury.
13. Keep clear of the workpiece near the area being fastened. Fasteners may bend sideways during firing, causing them to exit the workpiece at an unexpected point, causing personal injury.
13. Do not fire fasteners into a workpiece that has people, utility lines, or other objects behind or inside it.
14. Keep balance while using this tool. Keep area below clear if working in an elevated location, and secure air hose to prevent falls from bystanders accidentally pulling on it.
15. Hold the tool away from head and body. During operation the tool may kick back causing injury.

Air Supply

NOTE Working pressure refers to the air line pressure set to the tool when the tool is under working conditions. Terms used throughout this manual are Cubic Feet per Minute (CFM) and Pounds per Square Inch (PSI).

Please refer to the typical air system layout recommended below.

▲ WARNING Read and understand the air compressor instruction manual thoroughly before using the tool. It contains important safety information pertaining to the use of the air compressor and air hoses.

1. Use only clean, dry, regulated compressed air as the power source.
2. Make sure that the air compressor being used for the tool operation supplies the correct output (CFM).
3. Have the tool in the "off" position when connecting the tool to the air supply.
4. Use 90 PSI/6.3 bar working pressure for the tool. High pressure and unclean air will shorten the life of the tool due to faster wear of the tool.
5. Drain water from the air compressor tank daily, as well as any condensation in the air lines. Water in the air line may enter the tool and cause damage to the tool mechanisms during operation.
6. Clean the tool air inlet screen filter for blockage weekly. Clean if necessary.
7. A 3/8" (inner diameter) air hose is recommended for air supply and airflow to get the optimum performance of tool.
8. A long air hose (usually over 26 ft/8 m) may cause up to 15 PSI/1.1 bar drop in pressure, so you need to set the output pressure of the air compressor higher to maintain the required working pressure at the tool.
9. Use proper hoses and fittings. It is not recommended to use quick change couplings directly on the tool. Tool vibration may cause damage or tool failure. Instead, use a lead hose that can connect directly to the tool, and a connect coupling between the air supply and hose.

- Check the hoses for wear or defects before each use. Make certain that all connections are secure.
- An individual air tool has its specification of air consumption (CFM). Check the specifications of your compressor to be sure that it can support both minimum CFM (cubic feet per minute) and PSI (pounds per square inch) required.

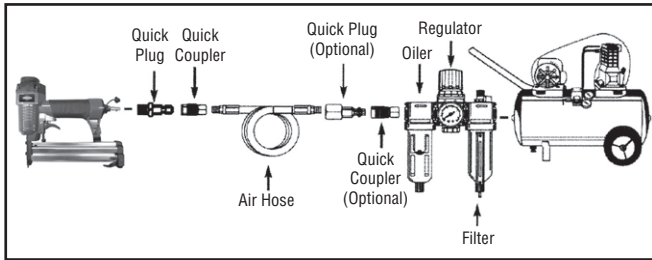

Product Description

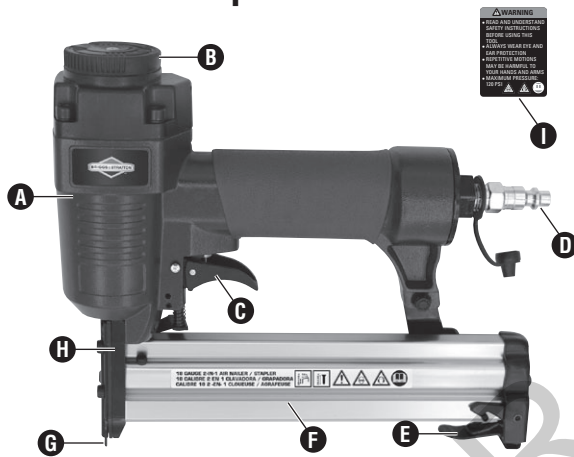

PART	DESCRIPTION	QUANTITY
A	Air Nailer/Stapler	1
B	Air Deflector	1
C	Trigger	1
D	Air Inlet	1
E	Magazine Latch	1
F	Magazine	1
G	Safety Nosepiece	1
H	Drive Guard	1
I	Warning Label	1

Technical Specifications

COMPONENT	SPECIFICATIONS
Magazine capacity	100 pieces
Operating pressure	60-100 PSI
Max. pressure	120 PSI
Avg. air consumption	1 CFM at 90 PSI
Safety mechanism type	single sequential
Nail size range	2/5 in. – 1-1/4 in. (10.16 mm – 31.75 mm) 18 gauge brad nails
Staple size range	2/5 in. – 1-1/4 in. 10.16 mm – 31.75 mm 18 gauge 1/4 in. (6.35 mm) crown staples
Air inlet	1/4 in. (6.35 mm) NPT (F)

Workpiece and Workplace Set Up

- Designate a work area that is clean and well lighted. The work area must not allow access to children or pets to prevent distraction and injury.
- Place the air hose along a safe route to reach the work area without creating a tripping hazard or exposing the air hose to possible damage. The air hose must be long enough to reach the work area with enough extra length to allow free movement while working.
- Secure loose workpieces using a vise or clamps (not included) to prevent movements while working.
- There must not be any hazardous objects such as utility lines or foreign objects nearby that will present a hazard while working.

Single sequential safety trip mechanism definition

This tool features the single sequential safety trip mechanism designed to prevent inadvertent firing. The tool should only fire when the safety nosepiece (G) is pressed against the workpiece prior to pulling the trigger (C). The tool should only fire again when the trigger is released and squeezed again. The tool should not fire when the safety nosepiece is not pressed against the workpiece.

Single sequential safety trip mechanism testing procedure

- Disconnect the tool from air supply.
- Empty the magazine (F) of fasteners.
- Check that the trigger (C) and safety nosepiece (G) move freely without sticking.
- Connect the tool to air supply. Set the working pressure at a range of 60 to 100 psi. Do not exceed the maximum pressure of 120 psi.
- Test the tool by pressing the safety nosepiece (G) against the workpiece without pulling the trigger (C). The tool must not cycle (fire). If it cycles, stop immediately and have it repaired by a qualified service technician.
- Hold the tool away, or off of the workpiece. The safety nosepiece (G) should return to its original position. Squeeze the trigger (C). The tool must not cycle. If it cycles, stop immediately and have it repaired by a qualified service technician.

7. Press the safety nosepiece against the workpiece and squeeze the trigger (C). The tool must cycle only once.
8. Release the trigger (C), slide the tool to a fresh piece of wood, and squeeze the trigger again. The tool must cycle again only once.
9. With the trigger (C) depressed, carefully lift the tool and press it against the workpiece again. The tool must not cycle. If it cycles, stop immediately and have it repaired by a qualified service technician.

Loading the tool

▲ WARNING Before loading the tool, detach the air supply. Then attempt to fire the tool into a piece of scrap wood to ensure that it is disconnected and is incapable of firing any fasteners.

1. This nailer/stapler can drive both 18 Gauge brad nails and 18 Gauge staples. These two types of fasteners are loaded in different ways.
2. Depress the magazine latch (E) and pull back on the moveable magazine, sliding it back to the end of the fixed magazine. (See Figure 1)

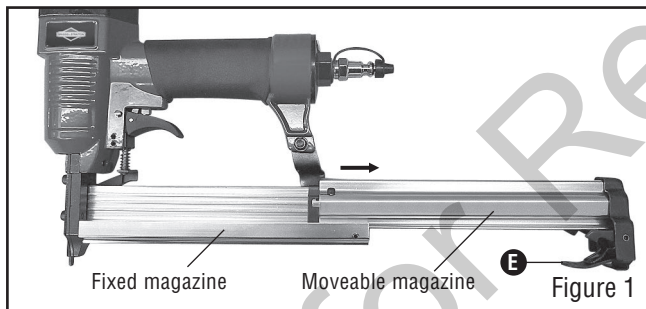

3. To load 18 Gauge brad nails, insert the nails into the channel along the right-side of the fixed magazine. (See Figure 2)

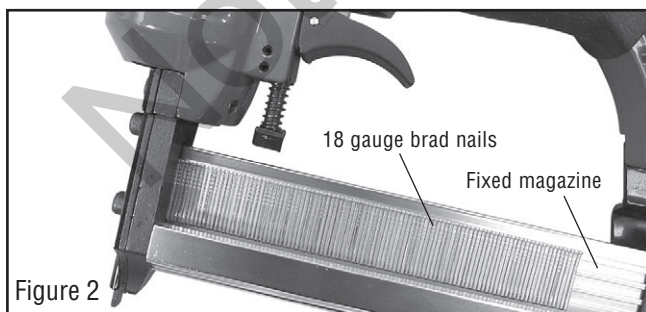

4. To load 18 Gauge staples, insert the staples from the top area of the fixed magazine with one arm of the staples in the center slot and the other arm along the fixed magazine's left side. (See Figure 3)

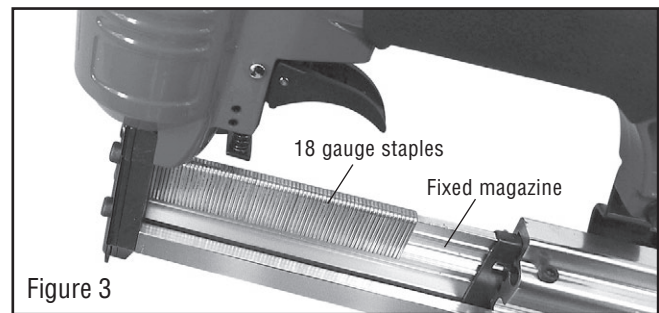

5. After the nails or staples are loaded, slide the moveable magazine back into the fixed magazine until the magazine latch (E) snaps back in place, securing the moveable magazine and locking the fasteners into place.

Operation Instructions

1. Place 2 -3 drops of air tool oil into the air inlet (D) before each use if an automatic oiler is not used.
2. Test the tool as described in the section of "Single sequential safety trip mechanism testing procedure".
3. Attach air supply hose to the air inlet (D). Start air compressor and check the pressure, making sure that the working pressure is within 60 - 100 psi as directed in the specifications. Never exceed the maximum pressure of 120 psi.

NOTE Working pressure refers to the air line pressure set to tool when tool is under working conditions.

4. To fire, place the safety nosepiece (G) on the workpiece. The tool should not fire when the safety nosepiece is not depressed. Once depressed, gently and briefly squeeze the trigger (C) once. Do not fire repeatedly, as nails or staples could bounce off of one another, damaging the workpiece or causing personal injury.

▲ WARNING

- To prevent serious injury, keep second hand away from tool discharge area, even when holding workpiece. Tool applies extreme force to fastener, and fasteners may deflect or fire in an unexpected direction.
- To prevent injury, do not hold the tool near body while firing. Tool recoil can cause injury.

5. If the tool requires more force to accomplish the task, verify that the tool receives sufficient, unobstructed airflow (CFM) and increase the pressure (PSI) output of the regulator up to the maximum air pressure rating of this tool. If the tool still does not have sufficient force at maximum pressure and sufficient airflow, then a larger tool may be required.

6. After use, release the trigger, and disconnect the tool from air supply. Attempt to fire the tool into a piece of scrap wood to ensure that it is disconnected and is incapable of firing any fasteners and that the residual air pressure should not be present after the tool is disconnected from air supply.

NOTE This tool features an air deflector (B) which can be rotated 360 degree by turning either clockwise or counter-clockwise to deflect air at any desired direction. (See Figure 4)

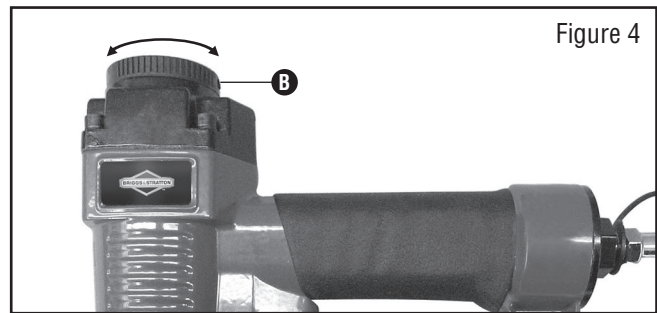

Figure 4

Troubleshooting

PROBLEM	POSSIBLE CAUSE	CORRECTIVE ACTION
Insufficient fastener depth.	<ol style="list-style-type: none"> 1. Not enough air pressure. 2. In correct lubrication or not enough lubrication. 3. Blocked air inlet screen (if equipped). 4. Mechanism contaminated. 	<ol style="list-style-type: none"> 1. Check for loose connections and ensure that air supply is providing enough air pressure (PSI) to the tool. 2. Lubricate using air tool oil and grease according to the directions. 3. Clean air inlet screen of buildup. 4. Have qualified technician clean and lubricate mechanism.
Fasteners drive too deeply.	Too much air pressure.	Reduce air supply pressure (PSI)
Tool cycles without firing fastener	<ol style="list-style-type: none"> 1. Jammed fastener. 2. Tool magazine empty. 3. Incorrect fasteners used. 4. Magazine dirty or not lubricated properly. 5. Insufficient air flow. 	<ol style="list-style-type: none"> 1. Clear jammed fastener according to the instructions in the manual. 2. Reload the tool. 3. Empty, then reload with correct fasteners. 4. Clean and lubricate the magazine and pusher. 5. Check for loose connections and ensure that air supply is providing enough air flow (CFM) and pressure (PSI) to the tool.
Frequent jamming.	Incorrect types of nail or staple	Check and confirm the correct types of nail and staple for use. Correct as needed.
Severe air leakage. (Slight air leakage is normal, especially on older tools.)	<ol style="list-style-type: none"> 1. Cross-threaded housing components. 2. loose housing. 3. Damaged valve or housing. 4. Dirty, worn or damaged valve. 	<ol style="list-style-type: none"> 1. Check for incorrect alignment and uneven gaps. If cross-threaded, disassemble and replace damaged parts before use. 2. Tighten housing assembly. If housing cannot tighten properly, internal parts may be misaligned. 3. Replace damaged components. 4. Clean or replace valve assembly.

Care and Maintenance

▲ WARNING To prevent serious injury from accidental operation, before any maintenance, repairs, or clearing jams, observe the following safety instructions:

1. Wear ANSI-approved safety goggles with side shields.
2. Release the trigger and disconnect the tool from air supply.
3. Attempt to fire the tool into a piece of scrap wood to ensure that it is disconnected and is incapable of firing any fasteners and that the residual air pressure should not be present after the tool is disconnected from air supply.
4. Empty the magazine and leave it open during service.

1. Before each use, inspect the general condition of the tool. Check for the proper safety trip mechanism operation, free safety nosepiece and trigger movement, misalignment or binding of moving parts, cracked or broken parts, and any other condition that may affect the tool's safe operation.
2. Clearing jams
 - 2.1. If a fastener is jammed in the magazine (F), depress the magazine latch (E) and pull back on the moveable magazine, sliding it back to the end of the fixed magazine.
 - 2.2. Use a screwdriver to release the jammed fastener by probing the openings in the fixed magazine.
 - 2.3. Pull out the jammed fastener and the remainder of the fastener strip that is still in the magazine (F). Dispose of the remaining fastener strip, since it is likely bent or damaged and may cause repeated jamming or damage to the tool if reused.
 - 2.4. If a fastener is jammed in the drive guard (H), disassemble the drive guard and then remove the jammed fastener. Pliers may be necessary to remove a stuck fastener in the drive guard.
 - 2.5. Inspect the drive guard (H) for any bends or breakage. If it is damaged, do not use the tool until it is repaired by a qualified service technician.
 - 2.6. Lightly oil the drive guard (H) with specified lubricants like white lithium grease. Replace the drive guard secure and make sure the safety nosepiece (G) moves without sticking.
 - 2.7. Reload the tool and then reconnect it to the air supply.
 - 2.8. Press the safety nosepiece (G) of the tool (A) against an appropriate piece of scrap wood.
 - 2.9. Test the tool several times, checking for proper operation.
 - 2.10. If the jam cannot be cleared using the above methods, have the tool serviced by a qualified technician.
3. After each use, disconnect the tool from air supply, remove the fasteners, clean the tool external surfaces with clean, dry cloth, and store the tool in a location out of reach of children.

Exploded Diagram

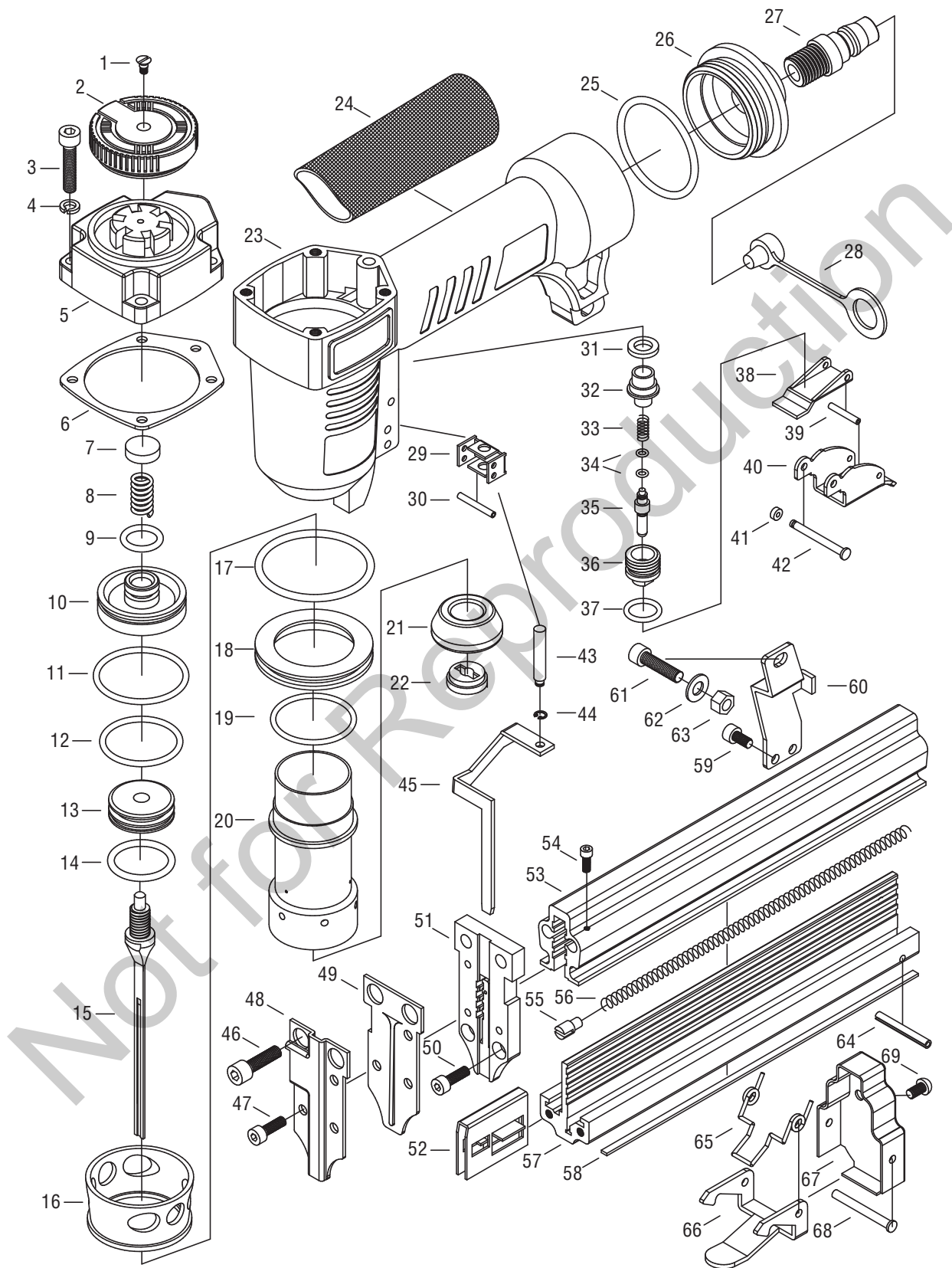

Parts List

Part No.	Description	Qty.
1	HEX. SOC. HD. blot	1
2	Air deflector	1
3	HEX. SOC.HD. blot	1
4	Washer	1
5	Exhaust cap	1
6	Sealing gasket	1
7	Rectangle washer	1
8	Compression spring	1
9	O-ring	1
10	Head valve piston	1
11	O-ring	1
12	O-ring	1
13	piston	1
14	O-ring	1
15	Driver	1
16	Collar	1
17	O-ring	1
18	Cylinder sleeve	1
19	O-ring	1
20	Cylinder	1
21	Bumper	1
22	Nozzle	1
23	Gun body	1
24	Rubber handle case	1
25	O-ring	1
26	End cup	1
27	Air plug	1
28	Air plug seal	1
29	Stand	1
30	Pin	1
31	Seal	1
32	Trigger valve seat	1
33	Spring	1
34	O-ring	2
35	Valve system	1

Part No.	Description	Qty.
36	Trigger valve guide	1
37	O-ring	1
38	Second trigger	1
39	Spring pin	1
40	Trigger	1
41	Rubber washer	1
42	Trigger pin	1
43	Safety pin	1
44	E-ring	1
45	Safety system	1
46	HEX. SOC. HD. blot	2
47	HEX. SOC. HD. blot	2
48	Safety cover	1
49	Driver guide cover	1
50	HEX. SOC. HD. blot	2
51	Driver guide	1
52	Pusher	1
53	Magazine seat	1
54	HEX. SOC. HD. blot	1
55	Handspike	1
56	Pusher spring	1
57	Magazine cap	1
58	Long pin	1
59	HEX. SOC. HD. blot	2
60	Stand	1
61	HEX. SOC. HD. blot	1
62	Washer	1
63	Screw	1
64	Trigger pin	1
65	Latch spring	1
66	Latch	1
67	Pusher stop	1
68	Rivet pin	1
69	HEX. SOC. HD. blot	1

Briggs & Stratton™ Air Tool Warranty Policy

January, 2016

LIMITED WARRANTY

Briggs & Stratton™ is a trademark of BRIGGS & STRATTON CORPORATION and is used under license to Alton Industry Co. Ltd© Alton Industry Co. Ltd warrants this Briggs & Stratton brand product for a period of one year from the date of original retail purchase against defects in materials and workmanship. Subject to the conditions and limitations described below, if Alton Industry Co. Ltd determines this product is covered under this warranty, it will be replaced with the same model or one of equal value or specification, at Alton Industry Co. Ltd's option. Alton Industry Co. Ltd will bear the cost of replacement. The purchaser must contact Alton Industry Co. Ltd© for all warranty authorizations.

There is no other express warranty. Implied warranties, including those of merchantability and fitness for a particular purpose, are limited to one year, or to the extent permitted by law. Liability for incidental or consequential damages are excluded to the extent exclusion is permitted by law. Some states or countries do not allow limitations on how long an implied warrant lasts, and some states or countries do not allow the exclusion or limitation of incidental or consequential damages, so the above limitation and exclusion may not apply to you. This warranty gives you specific legal rights and you may also have other rights which vary from state to state or country to country.

Save your proof of purchase receipt. If you do not provide proof of the initial purchase date at the time warranty service is requested, the manufacturing date of the product will be used to determine the warranty period. Product registration is not required to obtain warranty service on Briggs & Stratton products.

These are our standard warranty terms, but occasionally there may be additional warranty coverage that was not determined at time of publication. For a listing of current warranty terms for your air tool, go to BRIGGSandSTRATTON.COM

This Limited warranty does not include the following:

- A. Parts that are worn or broken or which have become inoperative due to abuse, misuse, accidental damage, neglect or lack of proper installation, operation or maintenance (as outlined in the applicable owner's manual or operating instructions) or product that has been used for industrial, professional, commercial or rental purposes;
- B. Normal wear and tear or expendable parts or accessories that may be supplied with the product which are expected to become inoperative or unusable after a reasonable period of use;
- C. Routine maintenance and consumable items such as, but not limited to fuel, lubricants, valves, belts, knobs, nuts, uids, tune-ups, or adjustments;
- D. Damage caused by repairs made or attempted by persons not authorized by the manufacturer;
- E. Product that was sold to the original purchaser as reconditioned or refurbished product (unless otherwise specied in writing);
- F. Product or parts thereof if any part from another manufacturer has been installed or any repairs or alterations have been made or attempted by unauthorized persons;
- G. Normal deterioration of the exterior nish such as, but not limited to, scratches, dents, paint chips, nor any corrosion or discoloring by heat, abrasive and chemical cleaners;
- H. Component parts sold by and identified as the product of another company, which shall be covered under the other product manufacturer's warranty, if any.

For questions about our warranty on this product, contact us at:

Alton Industry LTD. Group
1031 North Raddant Road
Batavia Illinois 60510
888-899-0146
info@altonindustries.com
www.altonindustries.com