

XR Engines



Quality and value, trusted for over a century.

XR 3.5 - 13.5 Gross HP*
Gasoline Engines



YOU.POWERED.™

XR Series gasoline engines: reliable, durable, powerful.

The Briggs & Stratton® XR Series of commercial engines are reliable and durable, designed to generate power for industries such as construction, industrial, landscaping, power generation and railway.

Long engine life

The XR engine utilizes various commercial design features to increase its robustness and durability. Components such as the cast iron cylinder sleeve, forged crankshaft and dual ball bearings have effectively extended engine life, enabling long-lasting use of the engines. Harsh laboratory tests and site examinations further ensures the XR engine's outstanding performance in machinery.

Easy start

Carefully configured and optimally designed, the carburetor, large inertia machinery decompression device and high-energy ignition system equipped the XR engine with excellent starting performance. Whether it is in a cold or hot state, the engine can start effortlessly.

Robust power

The OHV and combustion chamber with computer-aided design boosts the engine's combustion efficiency, strengthening its power output and reducing fuel consumption.



	XR 3.5	XR 5.0	XR 6.5	XR 10.0	XR 13.5
Model	0831	1062	130G	19N1	25T2
Gross Power (HP)*@3600rpm	3.5	5.0	6.5	10.0	13.5
Displacement (cc)	127	163	208	306	420
Bore x Stroke (in)	2.44 x 1.65	2.68 x 1.77	2.76 x 2.13	3.23 x 2.28	3.54 x 2.6
Fuel capacity (gal)	0.5	0.8	0.8	0.8	1.709
Oil capacity (oz)	20	20	20	37	37
Weight (lbs)	29.5	33.6	33.5	57.4	71.6
Measurements (L x W x H) (in)	10.1 x 13.4 x 13.4	11.3 x 14.6 x 14.0	11.3 x 14.4 x 14.9	12.6 x 17.0 x 16.5	14.5 x 18.1 x 18.3
Optional Configurations	6:1 gear reduction	Oil bath air filter Plate air filter	Oil bath air filter Plate air filter 2:1 gear reduction 12V electric start 1.5A & 3A alternator 6:1 gear reduction	Plate air filter 12V electric start 3A & 10A alternator	Plate air filter 12V electric start 3A & 10A alternator

2-Year Commercial Warranty, 2-Year Consumer Limited Warranty***

* Power levels are stated gross horsepower per SAE J1940 as rated by Briggs & Stratton.

** Briggs & Stratton reserves the right to change product specifications without prior notice.

*** See briggsandstratton.com for warranty information.

XR 3.5 Gross HP*

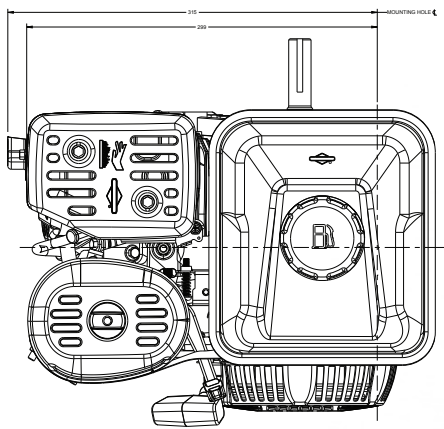

Top

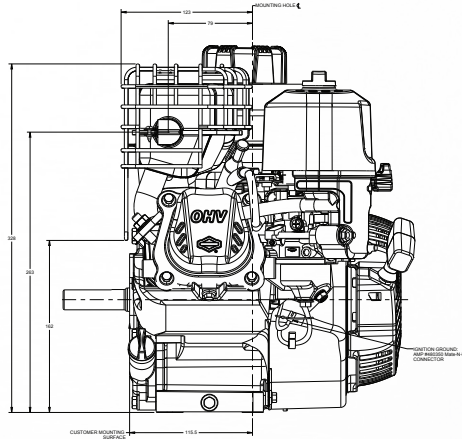

Side

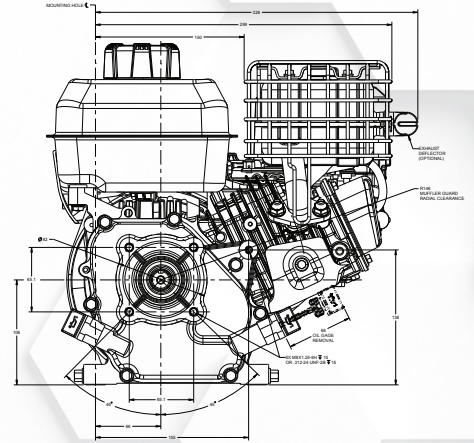

PTO

3/4" straight keyway shaft

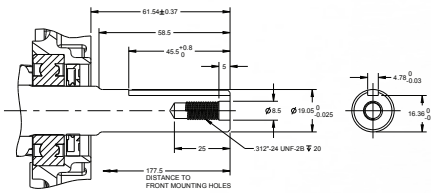

5/8" straight keyway shaft

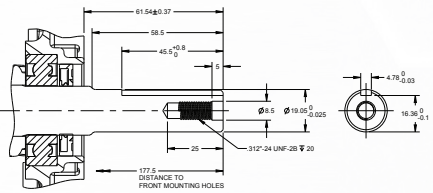

5/8" straight keyway shaft

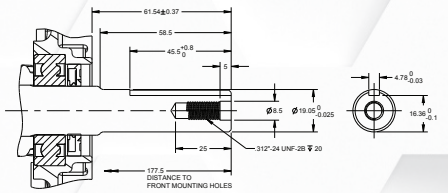

18mm straight keyway shaft

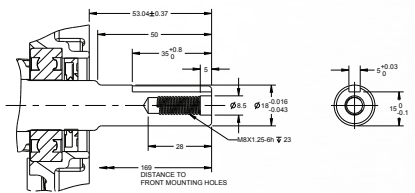

SAE tapered shaft

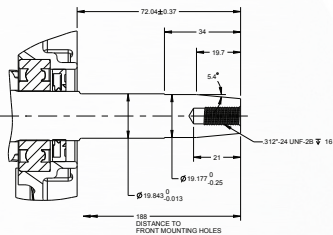

5/8" external thread shaft

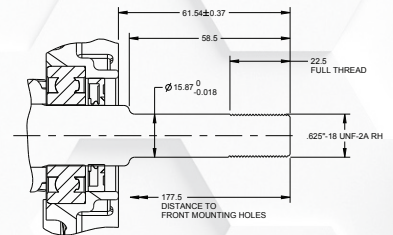

Gross Power*

0831 3.5 HP Gross Power

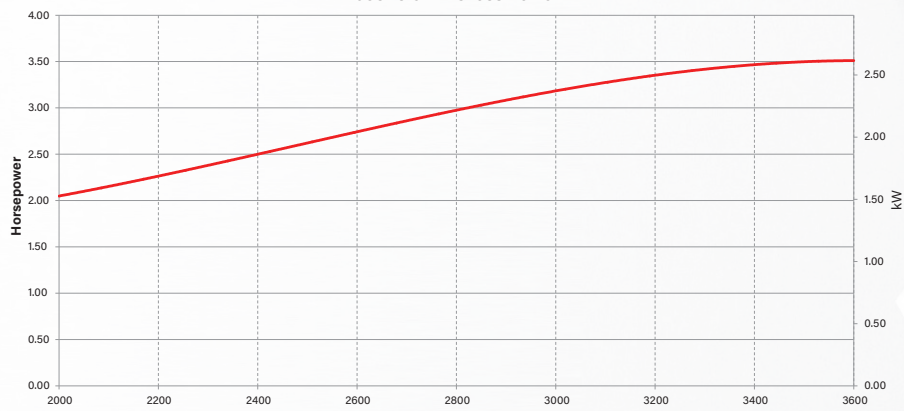

XR 5.0 Gross HP*

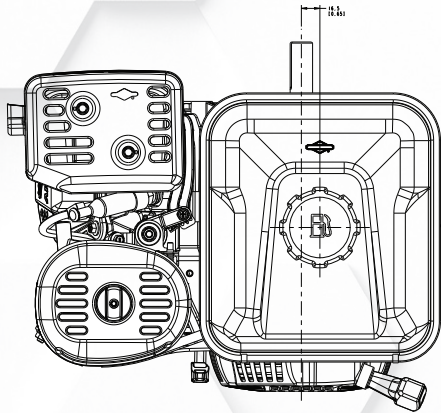

Top

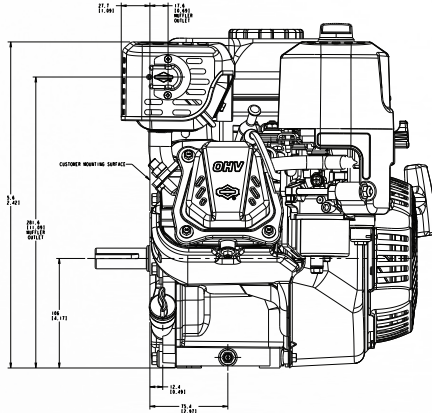

Side

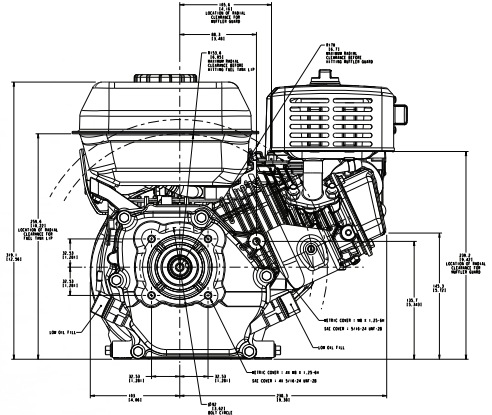

PTO

3/4" Straight Keyway Shaft

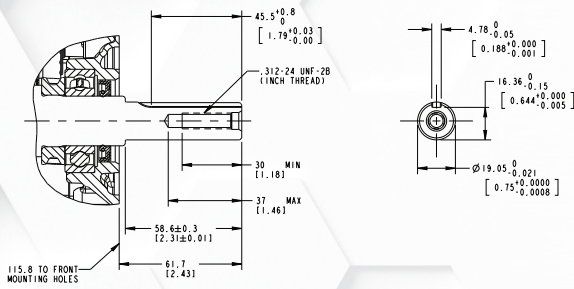

20mm Straight Keyway Shaft

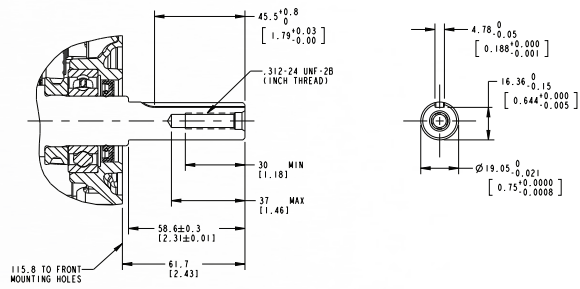

7/8" Tapered Shaft

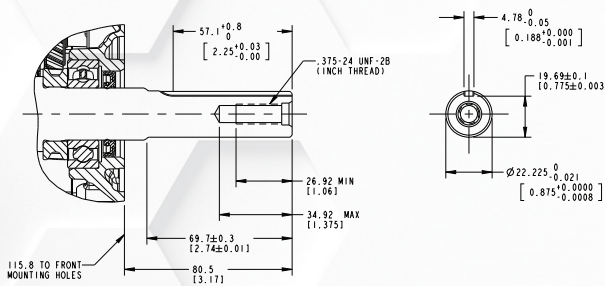

5/8" External Thread Shaft

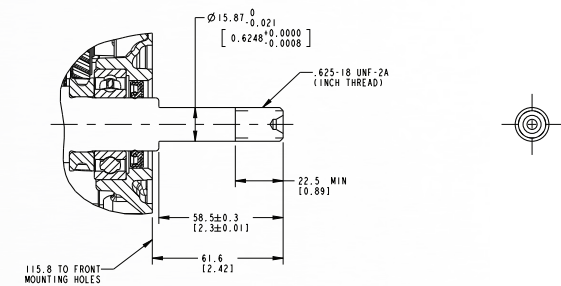

1062 5.0 HP Gross Power

Gross Power*

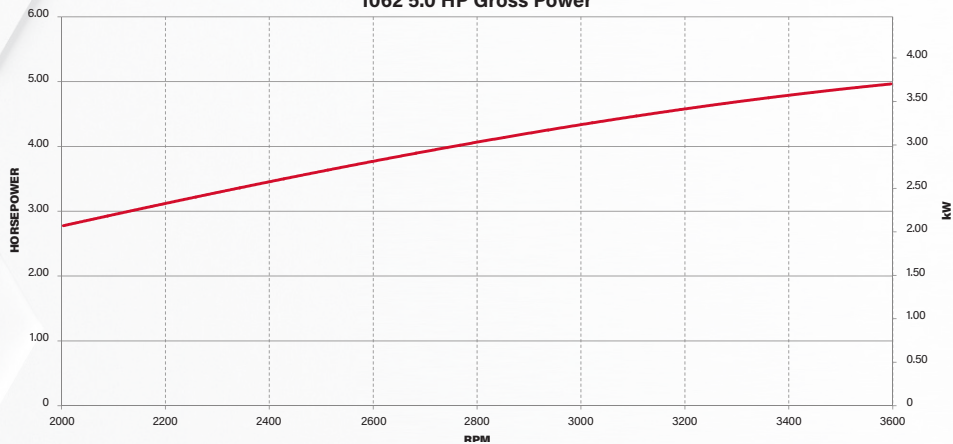

XR 6.5 Gross HP*

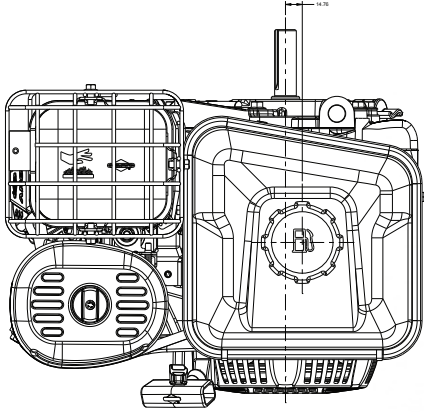

Top

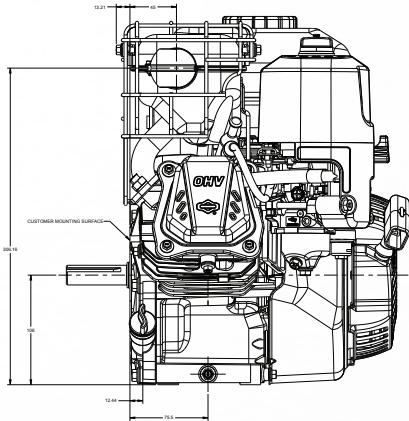

Side

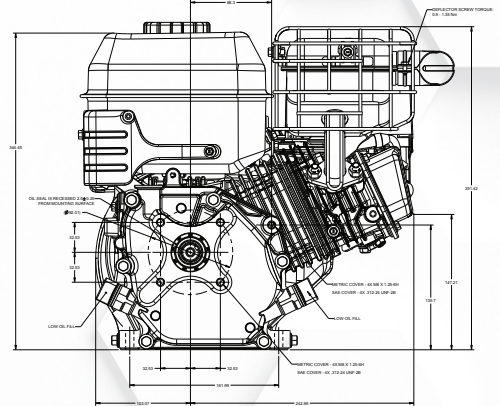

PTO

3/4" Straight Key

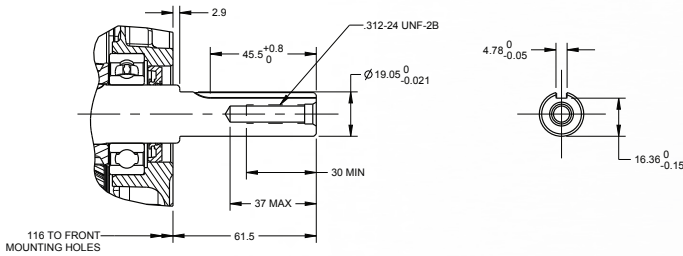

20mm Straight Key

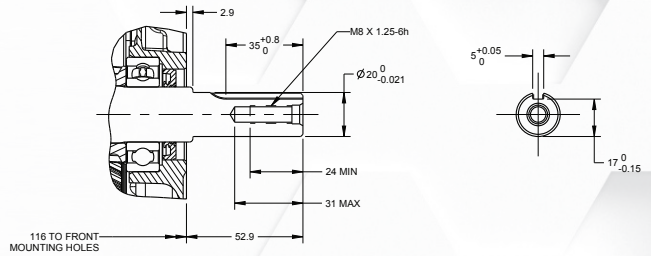

7/8" Straight Key

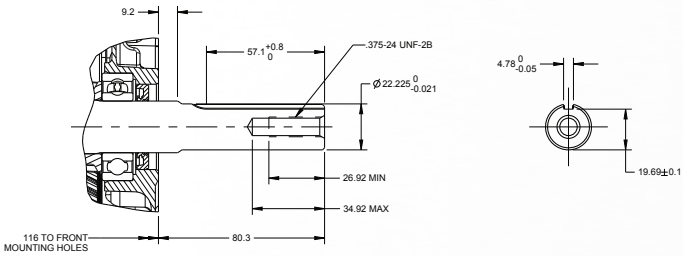

3/4" Taper Key

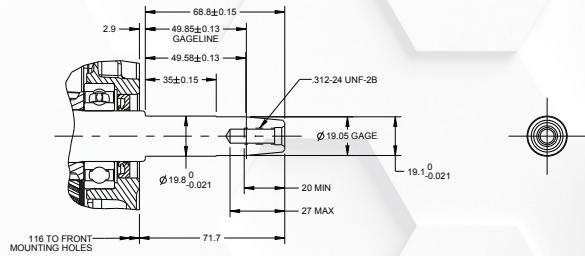

Gross Power*

130G 6.5 HP Gross Power

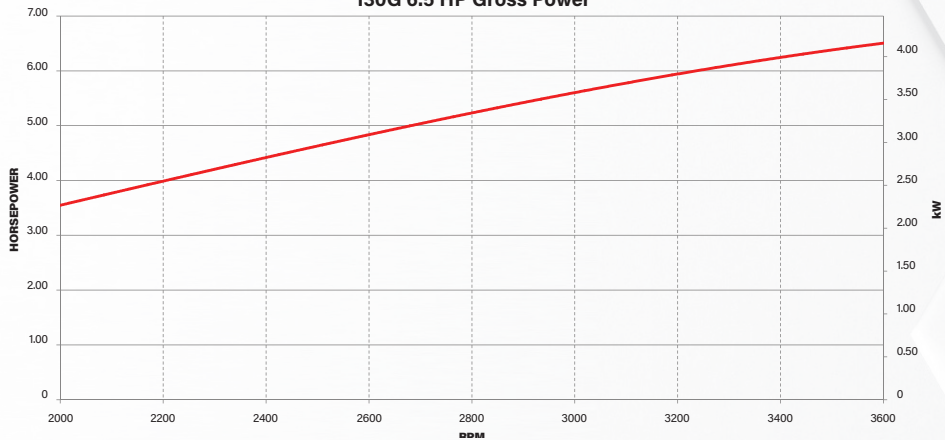

XR 10.0 Gross HP*

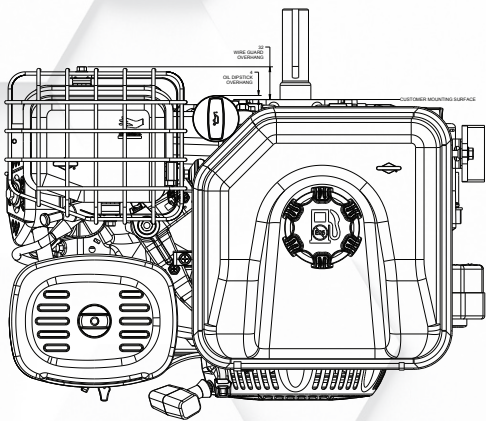

Top

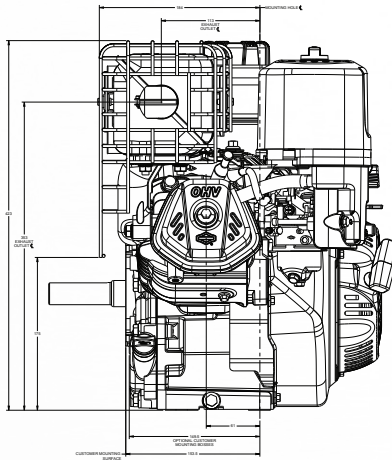

Side

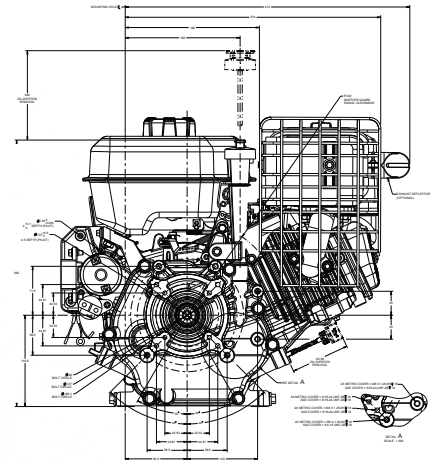

PTO

3/4" Straight Keyway Shaft

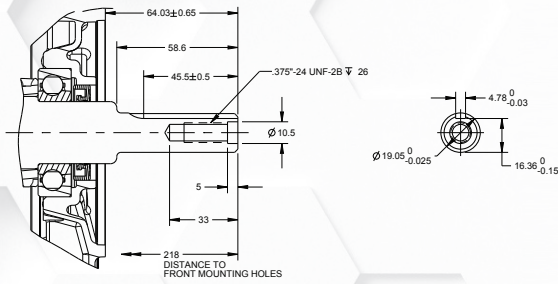

1" Tapered Shaft

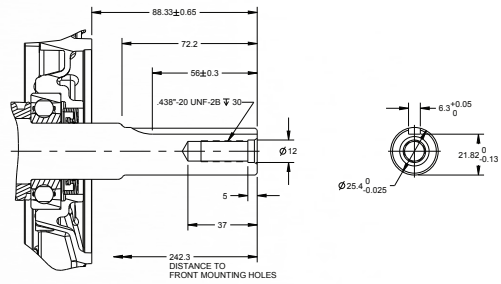

1" External Thread

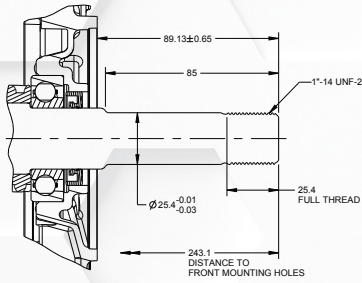

25mm Straight Keyway Shaft

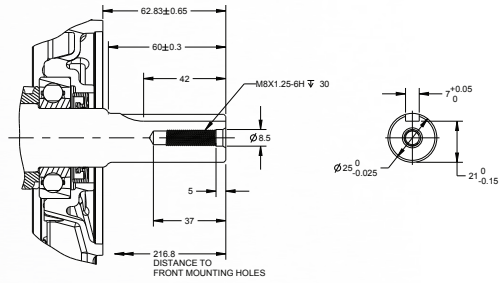

19N1 10.0 HP Gross Power

Gross Power*

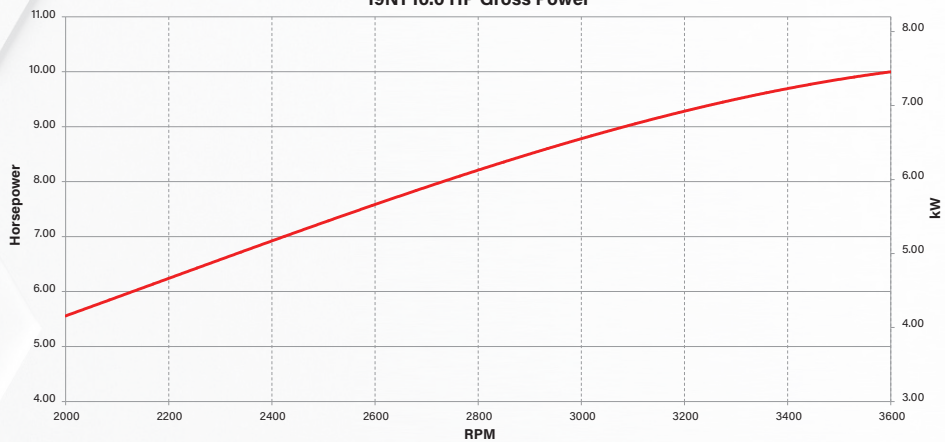

XR 13.5 Gross HP*

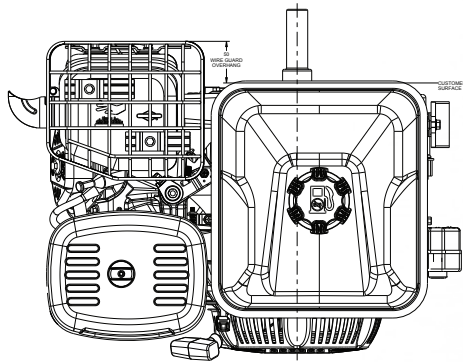

Top

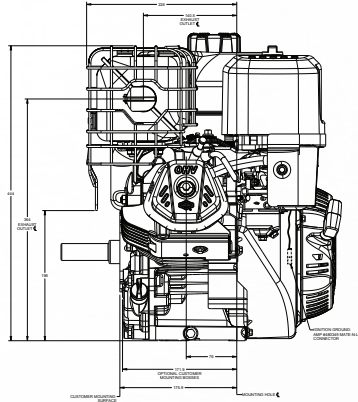

Side

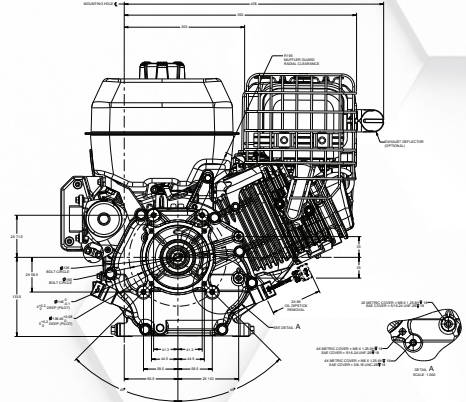

PTO

1" Straight Keyway Shaft

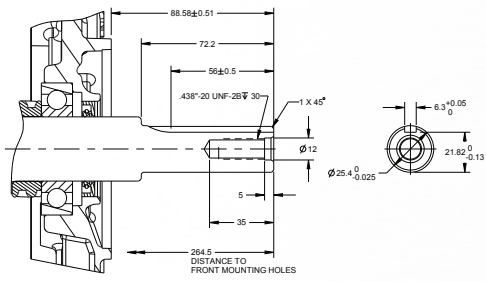

25mm Straight Keyway Shaft

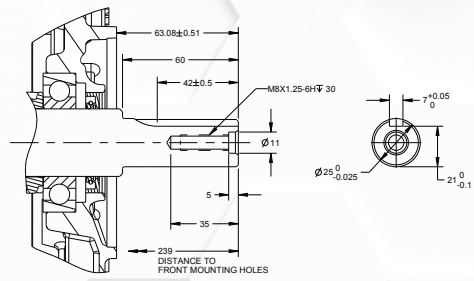

SAE Taper Shaft

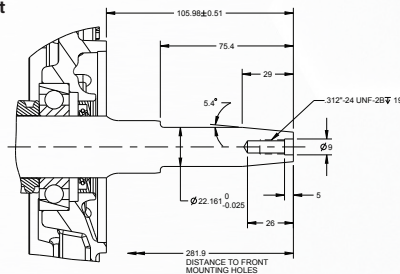

Gross Power*

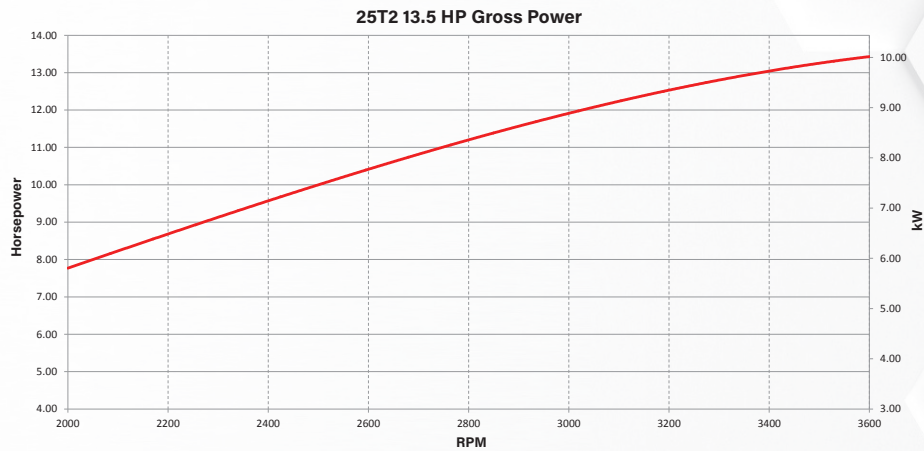

[BRIGGSandSTRATTON.com](https://www.BRIGGSandSTRATTON.com)

Briggs & Stratton has a policy of continuous product improvement and reserves the right to modify its specifications at any time and without prior notice. Product may vary from images shown.

BRIGGS & STRATTON
POST OFFICE BOX 702
MILWAUKEE, WI 53201 USA

Copyright ©2022. All rights reserved.

